

# 3250 Gal. Three Compartment Single Auto Siphon Septic Tank

FLXX®

FLXX®

**Total Capacity: 3365 gallons**

- Tank meets ASTM-C-1227 Spec. for water and wastewater structures.
- Various lid and riser options available.

PLAN

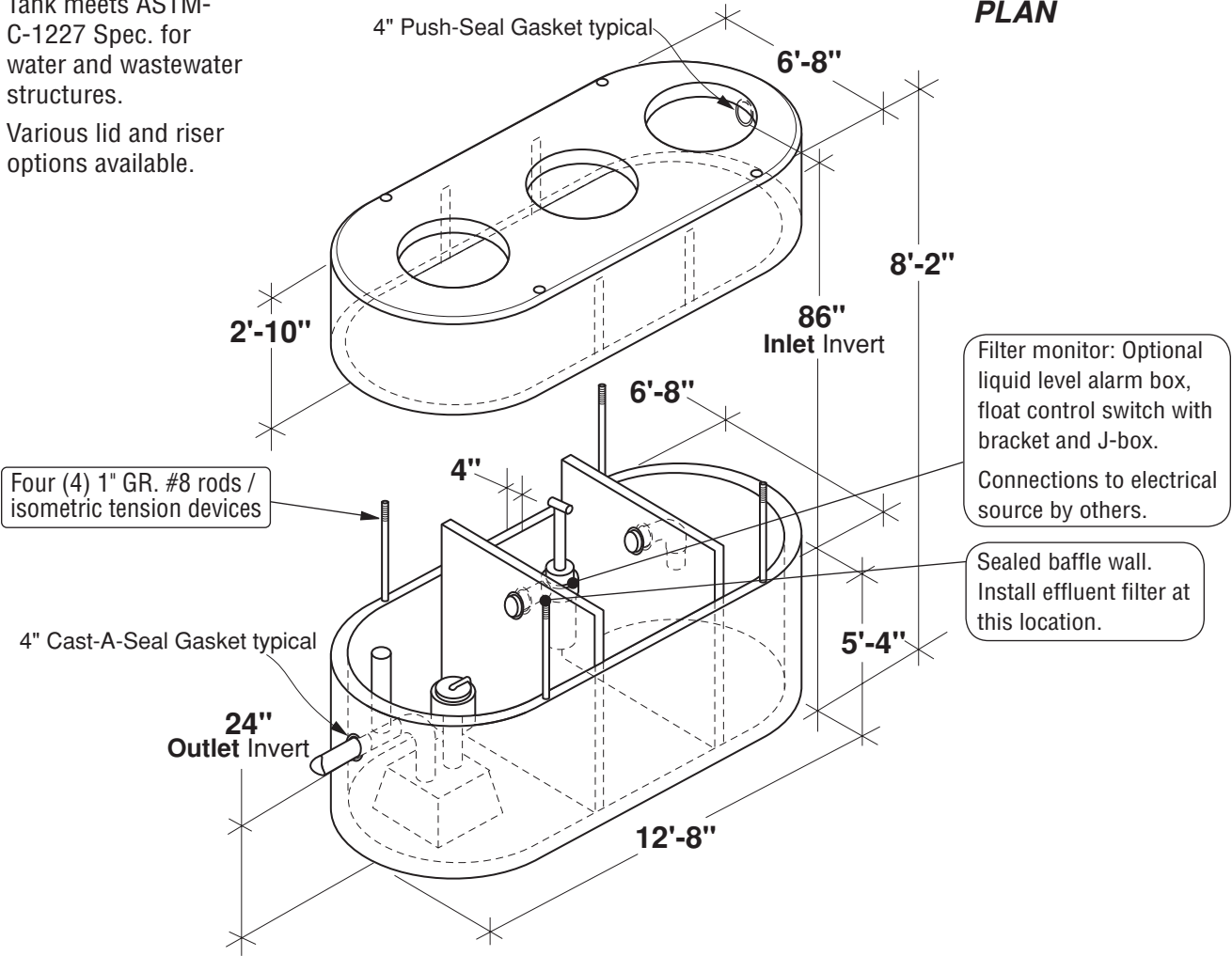

\* Includes 200 lbs. siphon / foundation

Part #	Capacities (gallons)		Siphon Chamber (gallons)	Siphon / Discharge		Approximate Weights			
	A	B		Tank*	Lid	Baffle Walls	Total		
PCA-001-293	1,685	815	865	#417	240 Gal.	11,890 lbs	7,715 lbs	3,180 lbs	22,785 lbs
PCA-002-293				#423	305 Gal.				

Note: N.T.S.

**FLXX®**   
**Watertight**  
**Front Range Precast Concrete, Inc.**  
 5439 N. Foothills Highway, Boulder, Colorado 80302  
 Phone (303) 442-3207 • (800) 783-3207 • Fax (303) 442-3209  
[www.flxx.com](http://www.flxx.com)