

# 3250 Gal. Three Compartment Electric Lift Septic Tank

FLXX®

FLXX®

**Total Capacity: 3365 gallons**

- Tank meets ASTM-C-1227 Spec. for water and wastewater structures.
- Various lid and riser options available.
- See pages 35 - 41 for pumps and controls.

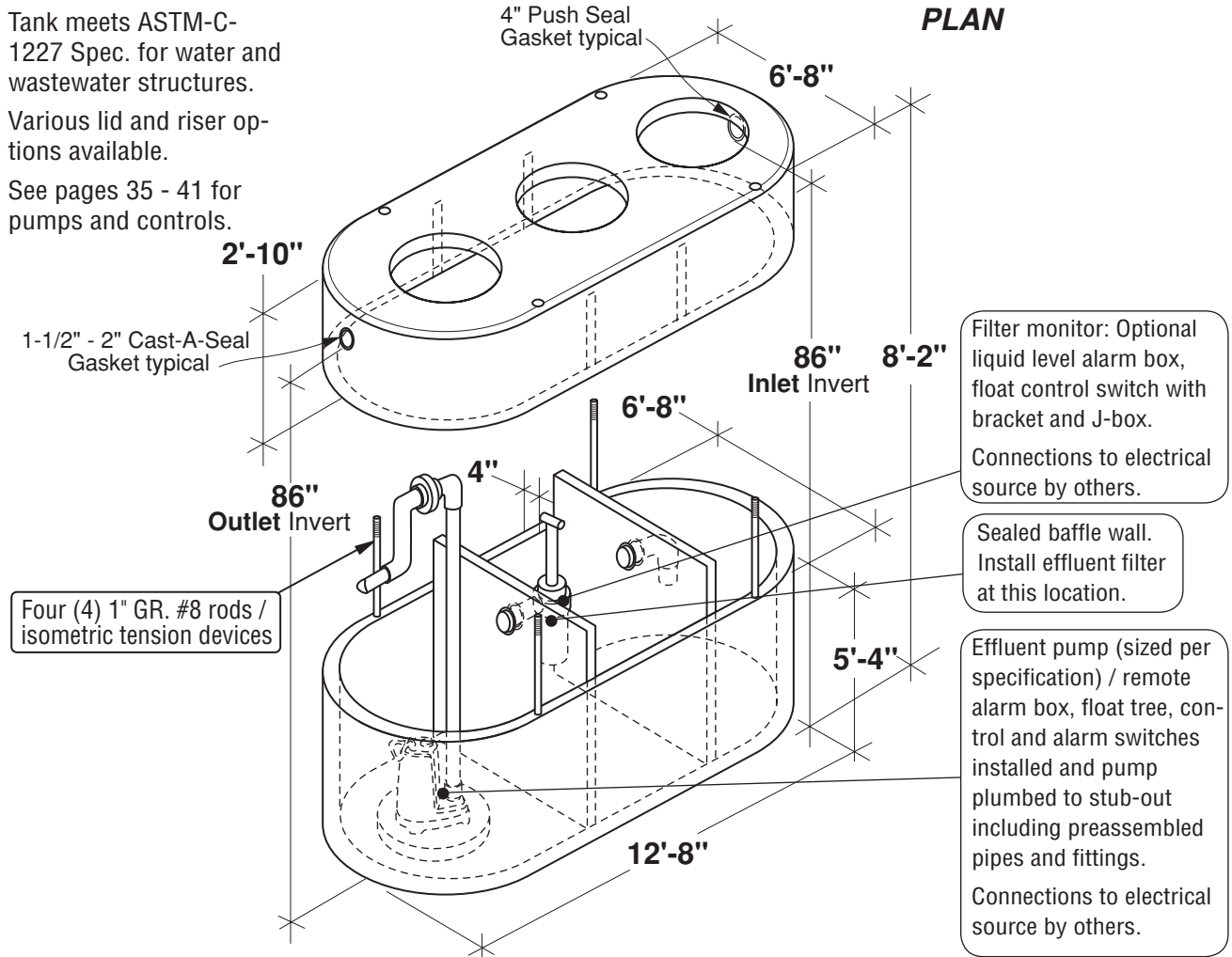

Part #	Capacities (gallons)		Lift Station Chamber (gallons)	Discharge Per Cycle	Approximate Weights			
	A	B			Tank	Lid	Baffle Walls	Total
PCA-000-342	1,685	815	865	Variable 10.5 Gal. / Vertical Inch	11,690 lbs	7,715 lbs	3,180 lbs	22,585 lbs

Note: N.T.S.

**FLXX®**   
**Watertight**  
**Front Range Precast Concrete, Inc.**  
 5439 N. Foothills Highway, Boulder, Colorado 80302  
 Phone (303) 442-3207 • (800) 783-3207 • Fax (303) 442-3209  
[www.flxx.com](http://www.flxx.com)