

2500 Gal. Three Compartment Electric Lift Septic Tank

FLXX®

FLXX®

Total Capacity: 2450 gallons

- Monolithic tank meets ASTM-C-1227 Spec. for water and wastewater structures.
- Butyl rubber sealant meets Fed. Spec. SS-S-210A. (Provided with tank)
- See pages 35 - 41 for pumps and controls.

PLAN

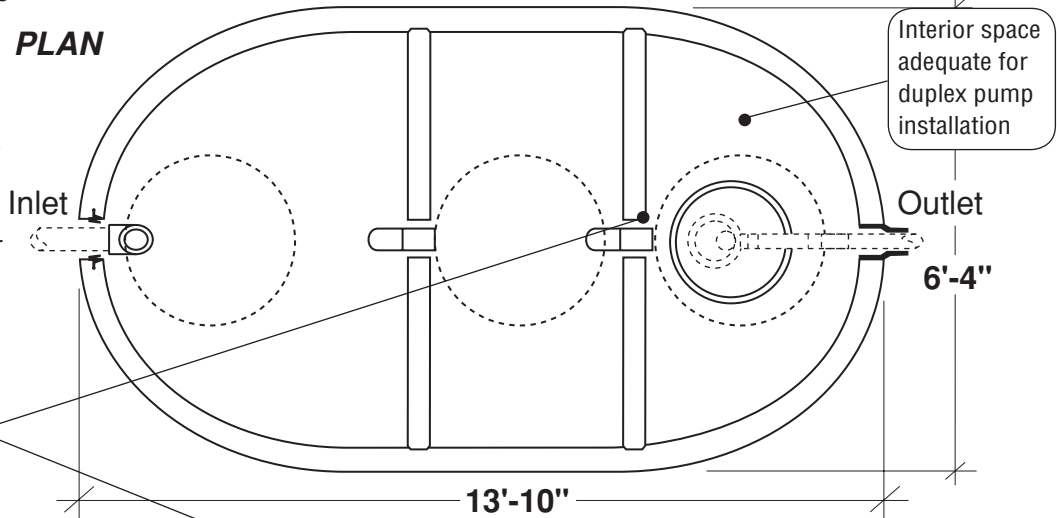

Sealed baffle wall. Install effluent filter at this location.

2' x 1' Modified riser w/ J-box float tree bracket

SECTION

4" Push Seal Gasket typical

2" Cast-A-Seal Gasket typical

Effluent pump (sized per specification) / remote alarm box, float tree, control and alarm switches installed and pump plumbed to stub-out including preassembled pipes and fittings. Connections to electrical source by others.

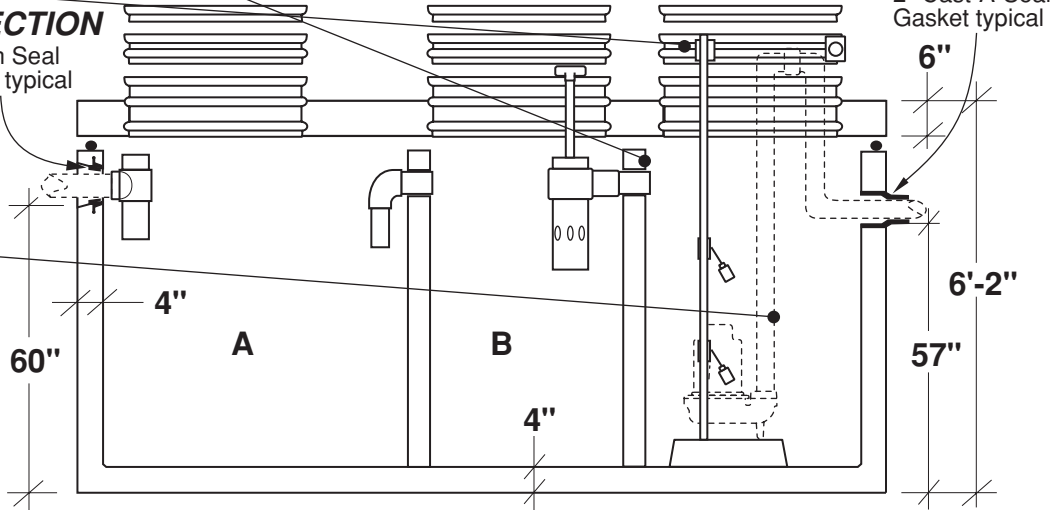

Part #	Capacities (gallons)		Lift Station Chamber (gallons)	Discharge Per Cycle	Approximate Weights			
	A	B			Tank	Lid	Baffle Walls	Total
PCA-000-355	1,145	780	525	Variable 11.2 Gal. / Vertical Inch	11,690 lbs	5,160 lbs	2,300 lbs	19,150 lbs

Note: N.T.S.

FLXX® 
Watertight

Front Range Precast Concrete, Inc.

5901 Dexter Street, Unit 200, Commerce City, CO 80022
Phone (303) 442-3207 • (800) 783-3207 • Fax (303) 442-3209
www.flxx.com