

1250 Gal. Three Compartment Dual Auto Siphon Septic Tank

FLXX®

FLXX®

Total Capacity: 1390 gallons

PLAN

Sealed baffle wall.
Install effluent filter at
this location.

Filter monitor: Optional liquid
level alarm box, float control
switch with bracket and J-box.
Connections to electrical source
by others.

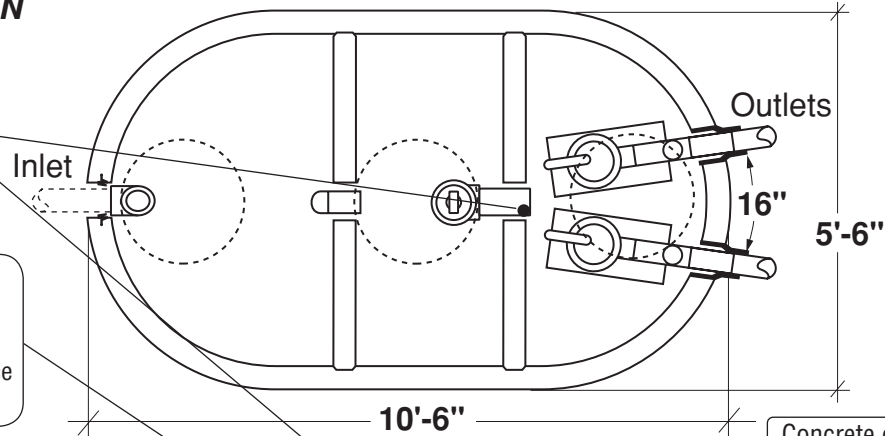

SECTION

4" Push Seal
Gasket typical

Concrete or heavy
duty polyethylene
riser system

- Monolithic tank meets ASTM-C-1227 Spec. for water and wastewater structures.
- Butyl rubber sealant meets Fed. Spec. SS-S-210A. (Provided with tank)
- All plumbing shown in diagram is 4" SDR 35. (Provided with tank)

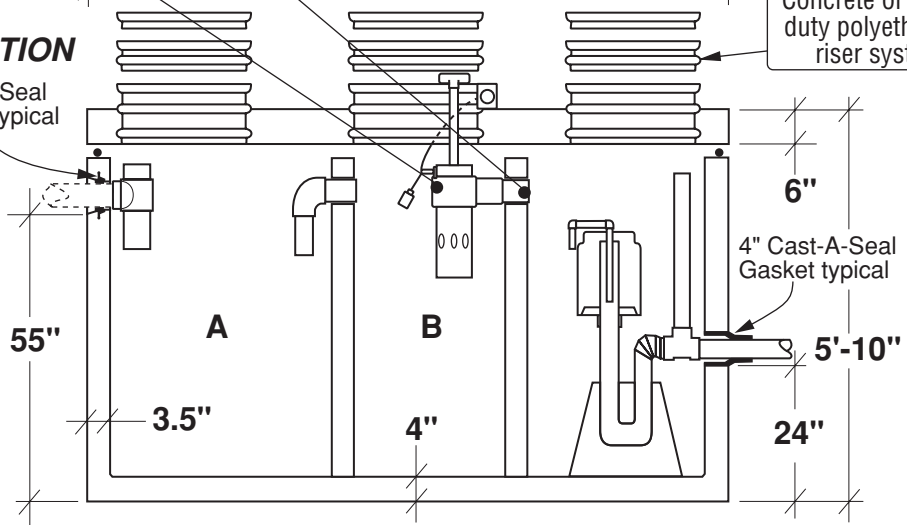

* Includes (2) 200 lbs. siphon / foundations

Part #	Capacities (gallons)		Siphon Chamber (gallons)	Siphon / Discharge		Approximate Weights			
	A	B		Tank*	Lid	Baffle Walls	Total		
PCA-000-339	640	420	330	#413	85 Gal.	8,830 lbs	3,370 lbs	1,820 lbs	14,020 lbs
PCA-001-339				#417	110 Gal.				
PCA-002-339				#423	150 Gal.				

Note: N.T.S.

FLXX® 
Watertight
Front Range Precast Concrete, Inc.
 5439 N. Foothills Highway, Boulder, Colorado 80302
 Phone (303) 442-3207 • (800) 783-3207 • Fax (303) 442-3209
www.flxx.com

1500 Gal. Three Compartment Dual Auto Siphon Septic Tank

FLXX®

FLXX®

Total Capacity: 1535 gallons

PLAN

Sealed baffle wall.
Install effluent filter at this location.

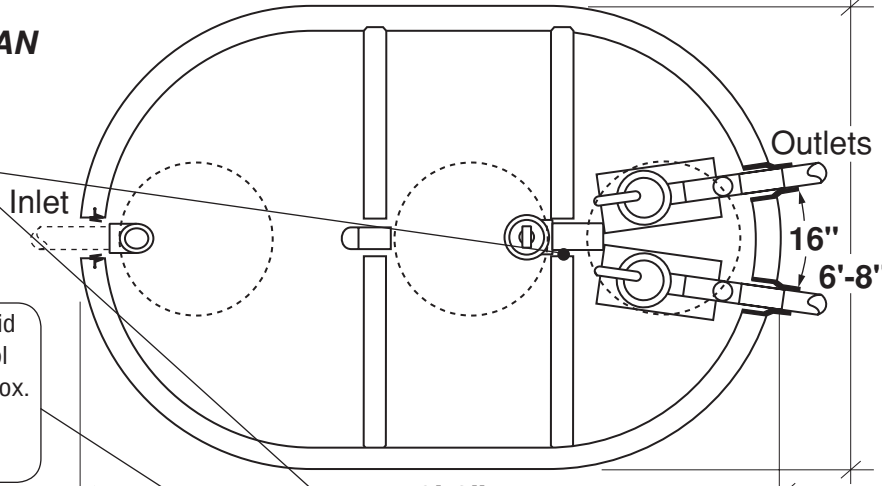

Filter monitor: Optional liquid level alarm box, float control switch with bracket and J-box.
Connections to electrical source by others.

SECTION

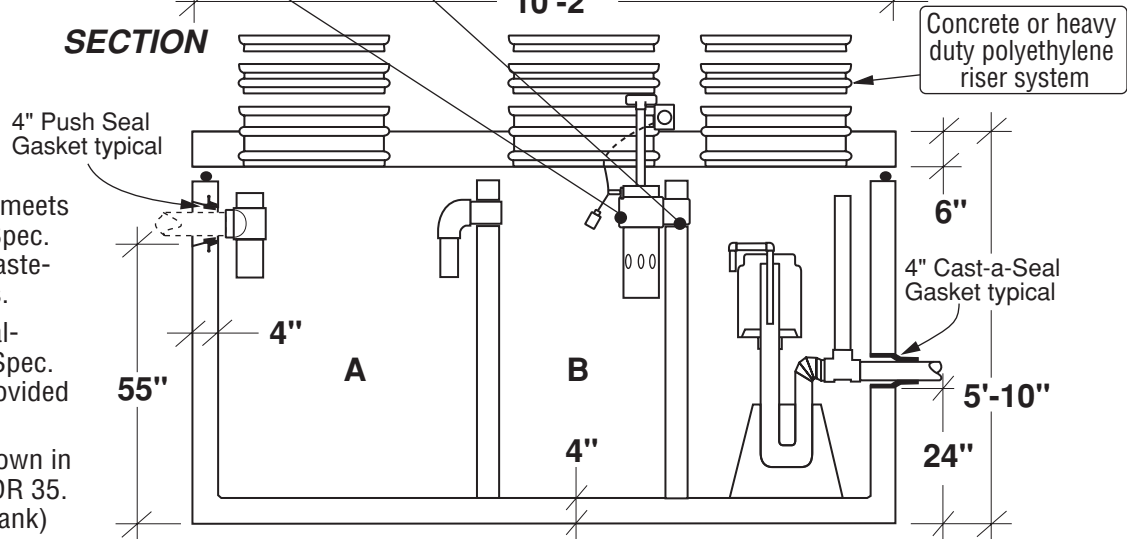

- Monolithic tank meets ASTM-C-1227 Spec. for water and wastewater structures.
- Butyl rubber sealant meets Fed. Spec. SS-S-210A. (Provided with tank)
- All plumbing shown in diagram is 4" SDR 35. (Provided with tank)

* Includes (2) 200 lbs. siphon / foundations

Part #	Capacities (gallons)		Siphon Chamber (gallons)	Siphon / Discharge		Approximate Weights			
	A	B		Tank*	Lid	Baffle Walls	Total		
PCA-000-264	675	450	410	#413	115 Gal.	10,015 lbs	3,900 lbs	2,220 lbs	16,135 lbs
PCA-001-264				#417	150 Gal.				
PCA-002-264				#423	200 Gal.				

Note: N.T.S.

FLXX® 
Watertight
Front Range Precast Concrete, Inc.
 5439 N. Foothills Highway, Boulder, Colorado 80302
 Phone (303) 442-3207 • (800) 783-3207 • Fax (303) 442-3209
www.flxx.com

2000 Gal. Three Compartment Dual Auto Siphon Septic Tank

FLXX®

FLXX®

Total Capacity: 2000 gallons

PLAN

Sealed baffle wall.
Install effluent filter
at this location.

Filter monitor: Optional
liquid level alarm box,
float control switch with
bracket and J-box.
Connections to electrical
source by others.

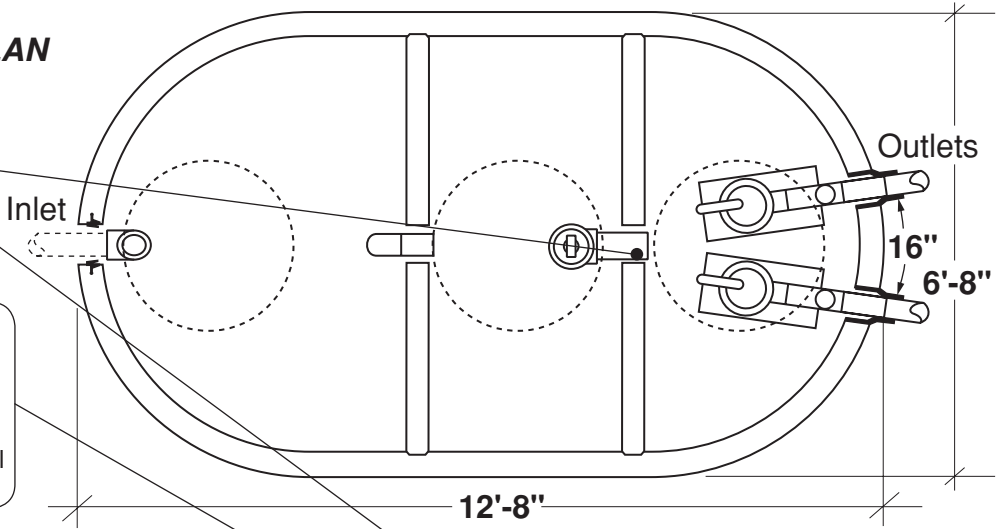

SECTION

Concrete or heavy
duty polyethylene
riser system

- Monolithic tank meets ASTM-C-1227 Spec. for water and wastewater structures.
- Butyl rubber sealant meets Fed. Spec. SS-S-210A. (Provided with tank)
- All plumbing shown in diagram is 4" SDR 35. (Provided with tank)

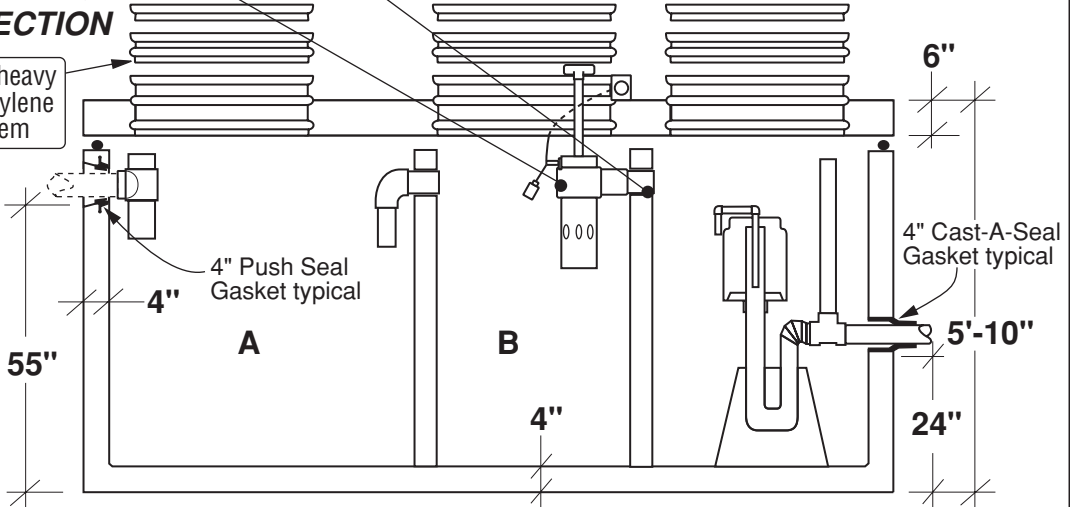

* Includes (2) 200 lbs. siphon / foundations

Part #	Capacities (gallons)		Siphon Chamber (gallons)	Siphon / Discharge		Approximate Weights			
	A	B		Tank*	Lid	Baffle Walls	Total		
PCA-000-340	1,000	500	500	#413	130 Gal.	12,090 lbs	5,145 lbs	2,220 lbs	19,455 lbs
PCA-001-340				#417	170 Gal.				
PCA-002-340				#423	230 Gal.				

Note: N.T.S.

FLXX® 
Watertight
Front Range Precast Concrete, Inc.
 5439 N. Foothills Highway, Boulder, Colorado 80302
 Phone (303) 442-3207 • (800) 783-3207 • Fax (303) 442-3209
www.flxx.com

2500 Gal. Three Compartment Dual Auto Siphon Septic Tank

FLXX®

FLXX®

Total Capacity: 2450 gallons

PLAN

Sealed baffle wall.
Install effluent filter
at this location.

Inlet

Outlets

16"

6'-4"

Filter monitor: Optional
liquid level alarm box,
float control switch with
bracket and J-box.

Connections to electrical
source by others.

13'-10"

SECTION

Concrete or heavy
duty polyethylene
riser system

6"

- Monolithic tank meets
ASTM-C-1227 Spec.
for water and waste-
water structures.

- Butyl rubber sealant
meets Fed. Spec. SS-
S-210A. (Provided
with tank)

- All plumbing shown
in diagram is 4" SDR
35. (Provided with
tank)

4" Push Seal
Gasket typical

A

B

4" Cast-A-Seal
Gasket typical

6'-2"

60"

4"

24"

* Includes (2) 200 lbs. siphon / foundations

Part #	Capacities (gallons)		Siphon Chamber (gallons)	Siphon / Discharge		Approximate Weights			
	A	B		Tank*	Lid	Baffle Walls	Total		
PCA-000-354	1,145	780	525	#413	135 Gal.	12,290 lbs	5,160 lbs	2,300 lbs	19,550 lbs
PCA-001-354				#417	180 Gal.				
PCA-002-354				#423	240 Gal.				

Note: N.T.S.

FLXX® 
Watertight

Front Range Precast Concrete, Inc.

5439 N. Foothills Highway, Boulder, Colorado 80302

Phone (303) 442-3207 • (800) 783-3207 • Fax (303) 442-3209

www.flxx.com

3250 Gal. Three Compartment Dual Auto Siphon Septic Tank

FLXX®

FLXX®

Total Capacity: 3365 gallons

- Tank meets ASTM-C-1227 Spec. for water and wastewater structures.
- Various lid and riser options available.

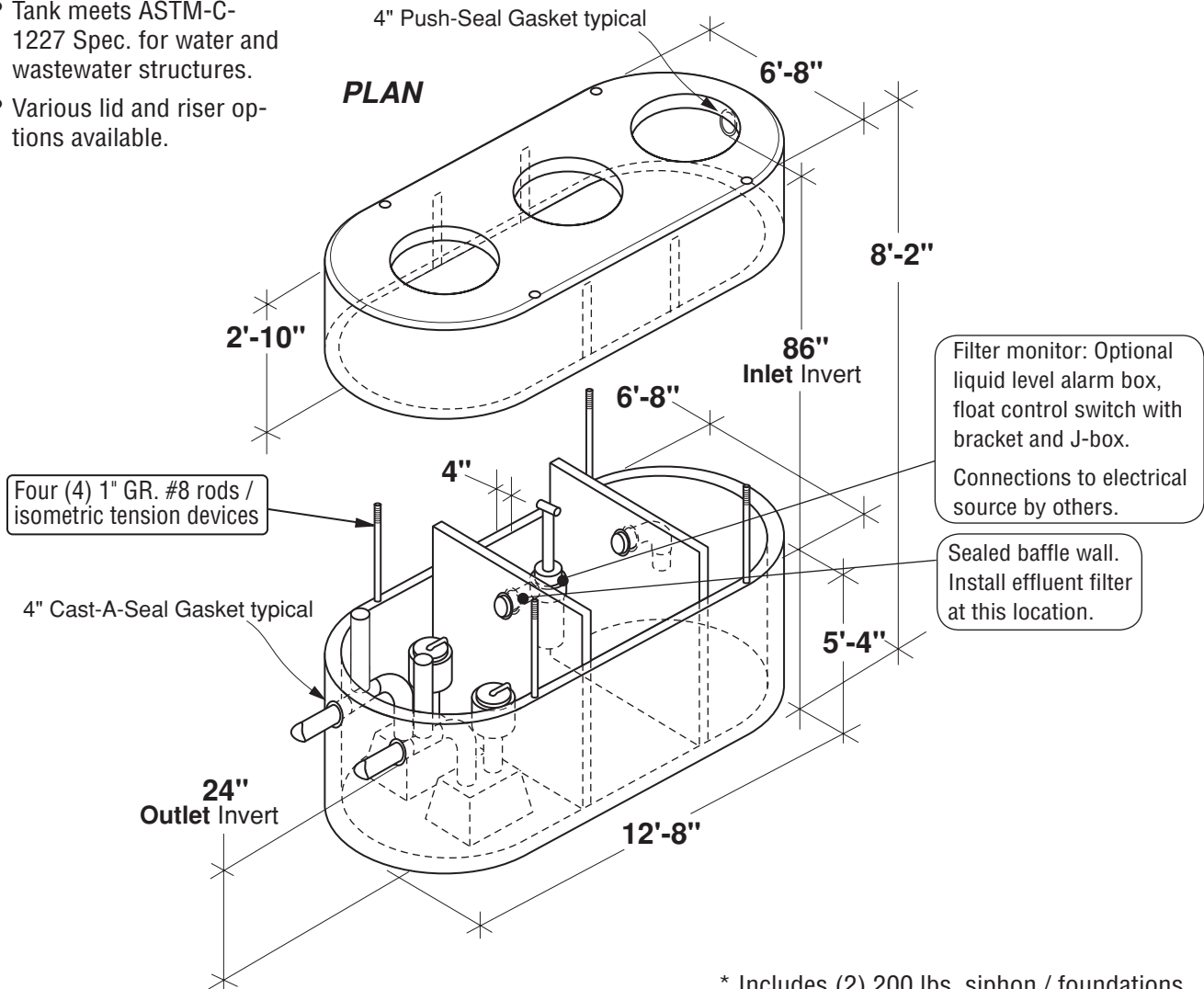

* Includes (2) 200 lbs. siphon / foundations

Part #	Capacities (gallons)		Siphon Chamber (gallons)	Siphon / Discharge		Approximate Weights			
	A	B		Tank*	Lid	Baffle Walls	Total		
PCA-001-341	1,685	815	865	#417	240 Gal.	12,090 lbs	7,715 lbs	3,180 lbs	22,985 lbs
PCA-002-341				#423	305 Gal.				

Note: N.T.S.

FLXX® 
Watertight
Front Range Precast Concrete, Inc.
 5439 N. Foothills Highway, Boulder, Colorado 80302
 Phone (303) 442-3207 • (800) 783-3207 • Fax (303) 442-3209
www.flxx.com