

3250 Gal. Three Compartment Dual Auto Siphon Septic Tank

FLXX®

FLXX®

Total Capacity: 3365 gallons

- Tank meets ASTM-C-1227 Spec. for water and wastewater structures.
- Various lid and riser options available.

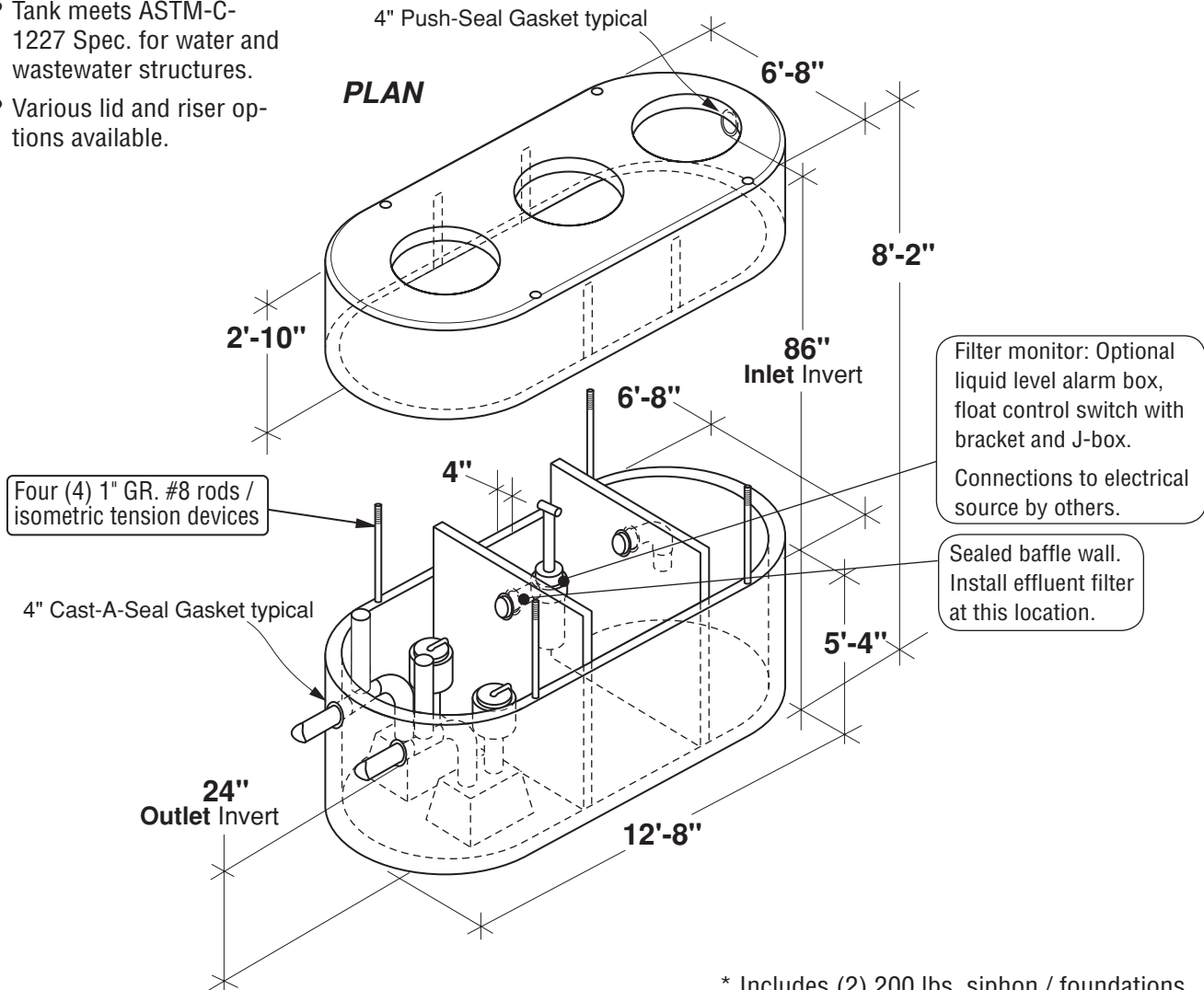

* Includes (2) 200 lbs. siphon / foundations

Part #	Capacities (gallons)		Siphon Chamber (gallons)	Siphon / Discharge		Approximate Weights			
	A	B		Tank*	Lid	Baffle Walls	Total		
PCA-001-341	1,685	815	865	#417	240 Gal.	12,090 lbs	7,715 lbs	3,180 lbs	22,985 lbs
PCA-002-341				#423	305 Gal.				

Note: N.T.S.

FLXX® 
Watertight
Front Range Precast Concrete, Inc.
 5439 N. Foothills Highway, Boulder, Colorado 80302
 Phone (303) 442-3207 • (800) 783-3207 • Fax (303) 442-3209
www.flxx.com