

1000 Gal. Two Compartment Septic Tank

FLXX®

FLXX®

- Monolithic tank meets ASTM-C-1227 Spec. for water and wastewater structures.
- Butyl rubber sealant meets Fed. Spec. SS-S-210A. (Provided with tank)
- All plumbing shown in diagram is 4" SDR 35. (Provided with tank)

PLAN

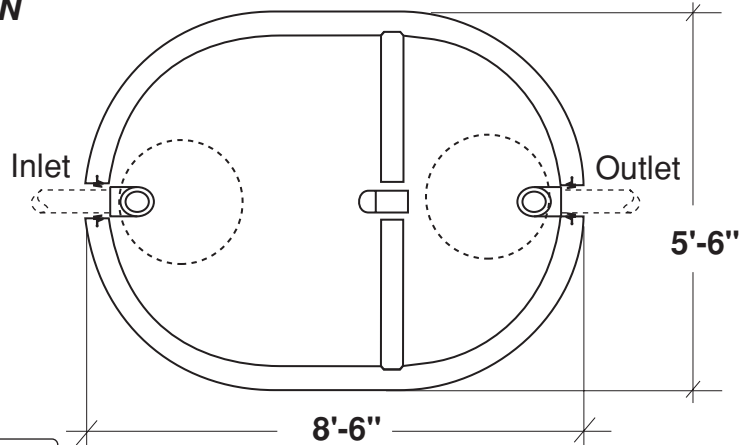

Concrete or heavy duty polyethylene riser system

SECTION

4" Push Seal Gasket typical

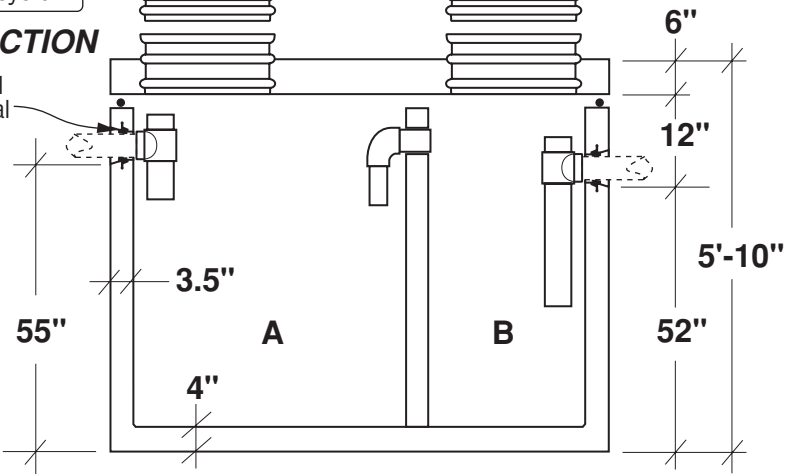

Part #	Capacities (gallons)		Approximate Weights			
	A	B	Tank	Lid	Baffle Wall	Total
PCA-000-252	640	430	6,995 lbs	2,550 lbs	910 lbs	10,455 lbs

Note: N.T.S.

FLXX® 
Watertight
Front Range Precast Concrete, Inc.
 5439 N. Foothills Highway, Boulder, Colorado 80302
 Phone (303) 442-3207 • (800) 783-3207 • Fax (303) 442-3209
www.flxx.com

1250 Gal. Two Compartment Septic Tank

FLXX®

FLXX®

- Monolithic tank meets ASTM-C-1227 Spec. for water and wastewater structures. **PLAN**
- Butyl rubber sealant meets Fed. Spec. SS-S-210A. (Provided with tank)
- All plumbing shown in diagram is 4" SDR 35. (Provided with tank)

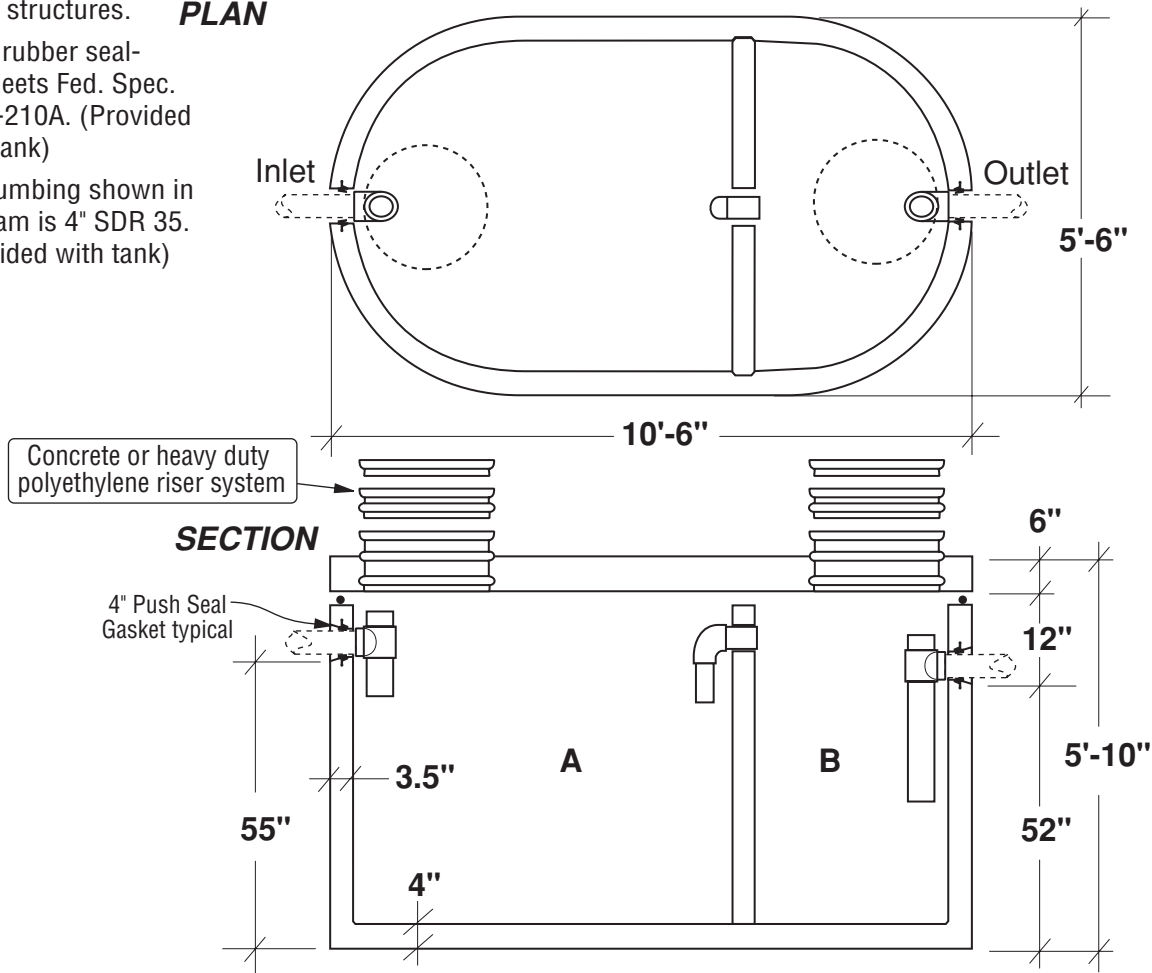

Part #	Capacities (gallons)		Approximate Weights			
	A	B	Tank	Lid	Baffle Wall	Total
PCA-000-254	835	555	8,430 lbs	3,370 lbs	910 lbs	12,710 lbs

Note: N.T.S.

FLXX® 
Watertight
Front Range Precast Concrete, Inc.
 5439 N. Foothills Highway, Boulder, Colorado 80302
 Phone (303) 442-3207 • (800) 783-3207 • Fax (303) 442-3209
www.flxx.com

1500 Gal. Two Compartment Septic Tank

FLXX®

FLXX®

- Monolithic tank meets ASTM-C-1227 Spec. for water and wastewater structures.
- Butyl rubber sealant meets Fed. Spec. SS-S-210A. (Provided with tank)
- All plumbing shown in diagram is 4" SDR 35. (Provided with tank)

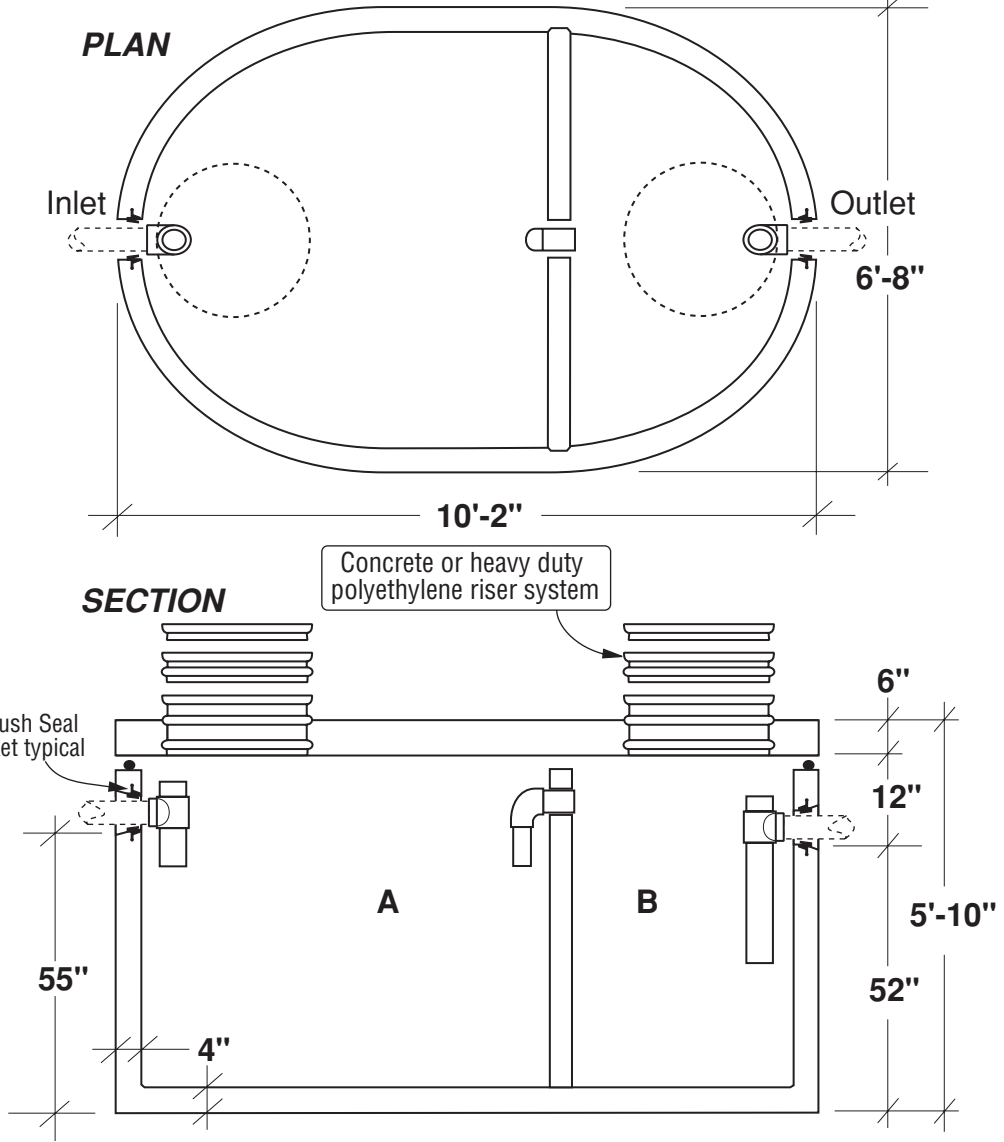

Part #	Capacities (gallons)		Approximate Weights			
	A	B	Tank	Lid	Baffle Wall	Total
PCA-000-256	920	615	9,615 lbs	3,900 lbs	1,110 lbs	14,625 lbs

Note: N.T.S.

FLXX® 
Watertight
Front Range Precast Concrete, Inc.
 5439 N. Foothills Highway, Boulder, Colorado 80302
 Phone (303) 442-3207 • (800) 783-3207 • Fax (303) 442-3209
www.flxx.com

2000 Gal. Two Compartment Septic Tank

FLXX®

FLXX®

- Monolithic tank meets ASTM-C-1227 Spec. for water and wastewater structures.
- Butyl rubber sealant meets Fed. Spec. SS-S-210A. (Provided with tank)
- All plumbing shown in diagram is 4" SDR 35. (Provided with tank)

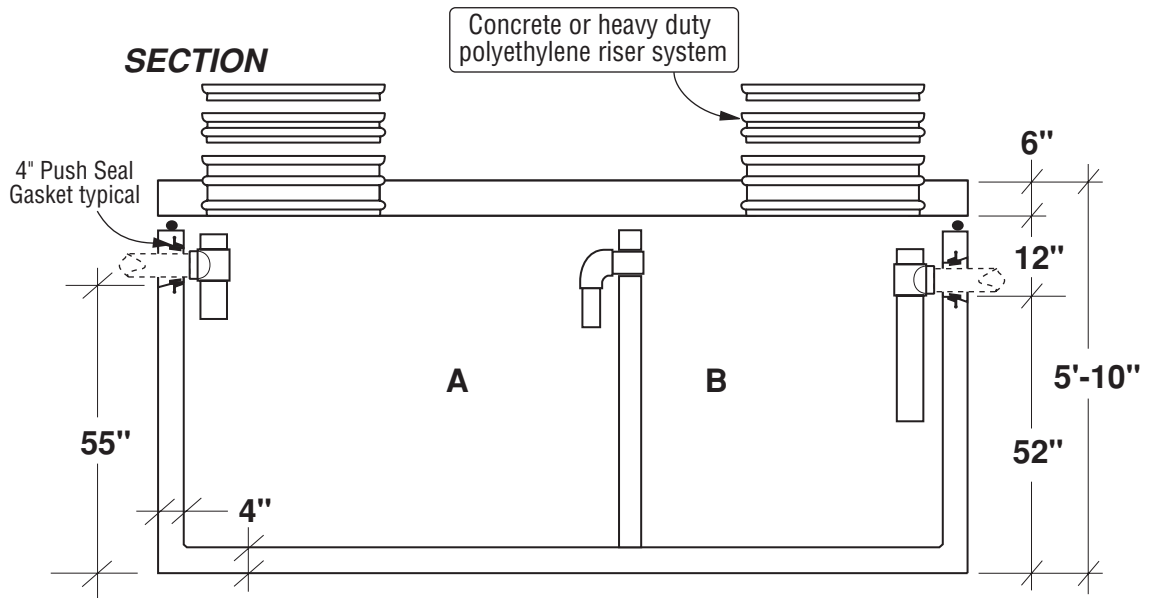
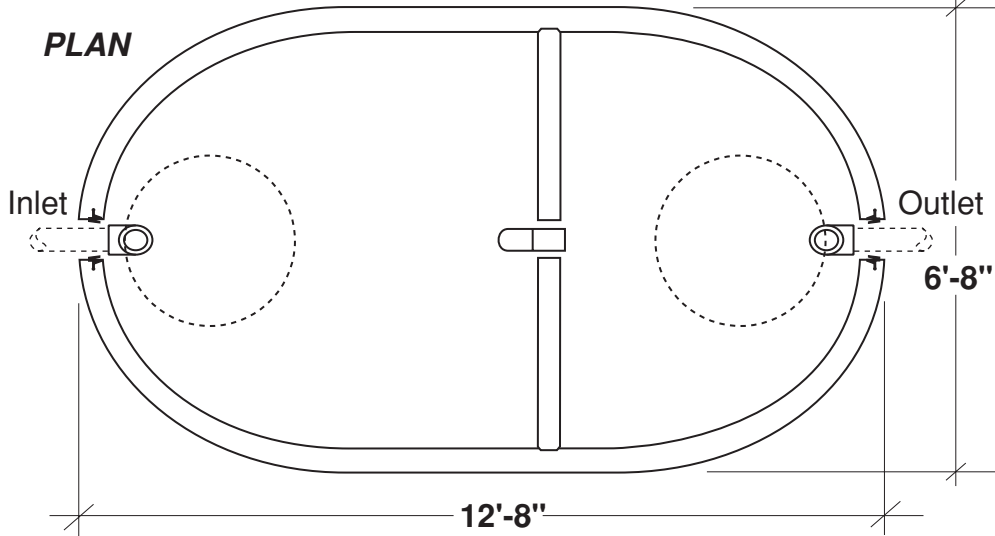

Part #	Capacities (gallons)		Approximate Weights			
	A	B	Tank	Lid	Baffle Wall	Total
PCA-000-258	1200	800	11,690 lbs	5,145 lbs	1,110 lbs	17,945 lbs

Note: N.T.S.

FLXX® 
Watertight
Front Range Precast Concrete, Inc.
 5439 N. Foothills Highway, Boulder, Colorado 80302
 Phone (303) 442-3207 • (800) 783-3207 • Fax (303) 442-3209
www.flxx.com

2500 Gal. Two Compartment Septic Tank

FLXX®

FLXX®

- Monolithic tank meets ASTM-C-1227 Spec. for water and wastewater structures.
- Butyl rubber sealant meets Fed. Spec. SS-S-210A. (Provided with tank)
- All plumbing shown in diagram is 4" SDR 35. (Provided with tank)

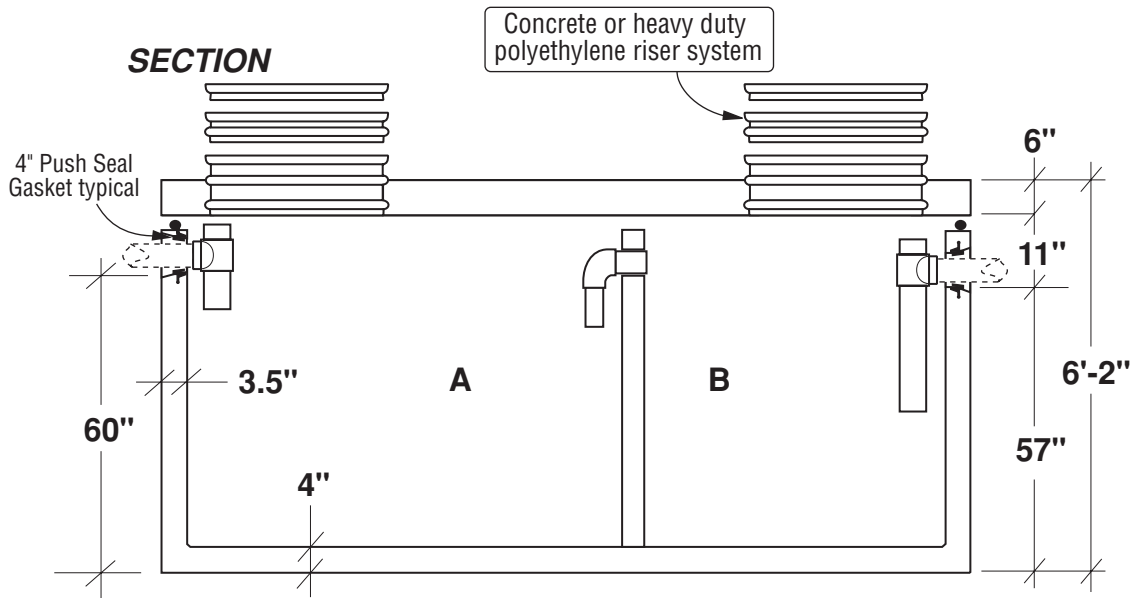
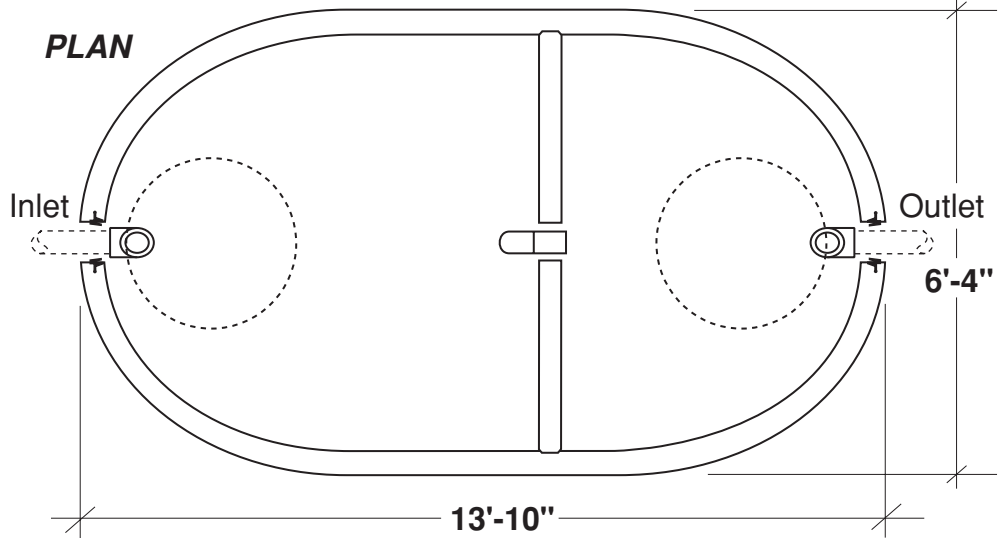

Part #	Capacities (gallons)		Approximate Weights			
	A	B	Tank	Lid	Baffle Wall	Total
PCA-000-325	1470	980	11,890 lbs	5,400 lbs	1,150 lbs	18,440 lbs

Note: N.T.S.

FLXX® 
Watertight
Front Range Precast Concrete, Inc.
 5439 N. Foothills Highway, Boulder, Colorado 80302
 Phone (303) 442-3207 • (800) 783-3207 • Fax (303) 442-3209
www.flxx.com

3250 Gal. Two Compartment Septic Tank/Vault

FLXX®

FLXX®

Total Capacity: 3290 gallons

- Tank meets ASTM-C-1227 Spec. for water and wastewater structures.
- Various lid and riser options available.
- Tank sections sealed using a polyurethane sealant and four (4) 1" grade #8 rods.

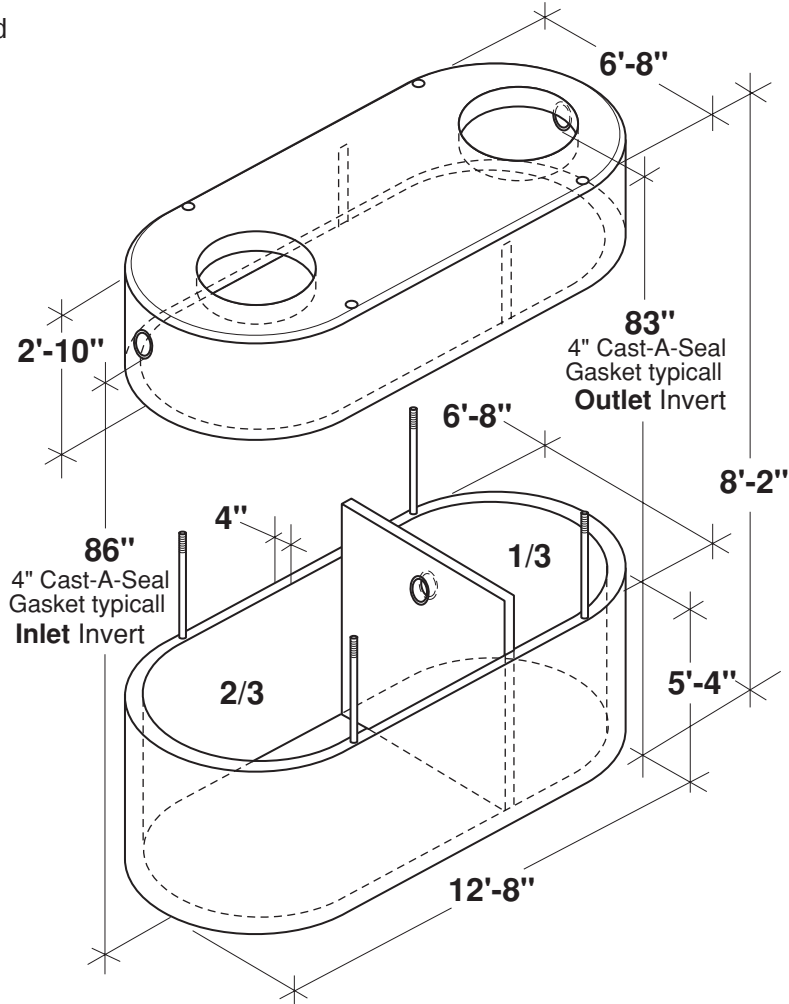

Part #	Capacities (gallons)		Approximate Weights			
	A	B	Tank	Lid	Baffle Wall	Total
PCA-000-316	1990	1300	11,690 lbs	7,715 lbs	1,590 lbs	20,995 lbs

Note: N.T.S.

FLXX® 
Watertight
Front Range Precast Concrete, Inc.
 5439 N. Foothills Highway, Boulder, Colorado 80302
 Phone (303) 442-3207 • (800) 783-3207 • Fax (303) 442-3209
www.flxx.com