

1000 Gal. Two Compartment Septic Tank

FLXX®

FLXX®

- Monolithic tank meets ASTM-C-1227 Spec. for water and wastewater structures.
- Butyl rubber sealant meets Fed. Spec. SS-S-210A. (Provided with tank)
- All plumbing shown in diagram is 4" SDR 35. (Provided with tank)

PLAN

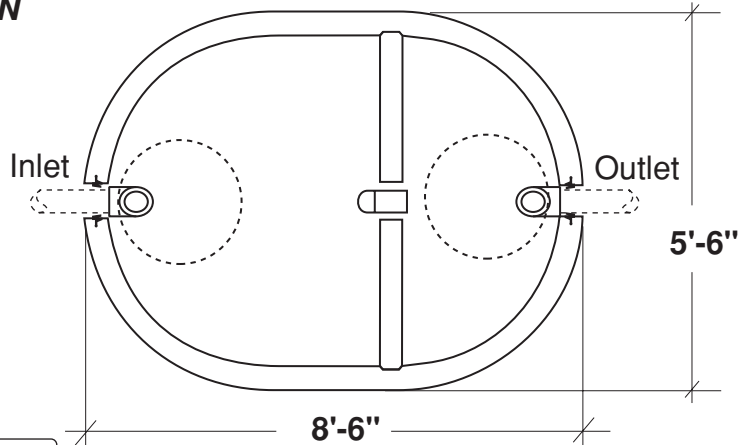

Concrete or heavy duty polyethylene riser system

SECTION

4" Push Seal Gasket typical

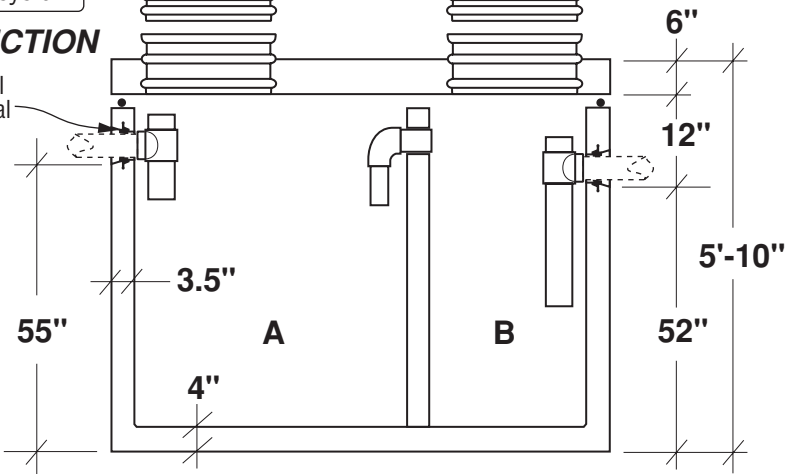

Part #	Capacities (gallons)		Approximate Weights			
	A	B	Tank	Lid	Baffle Wall	Total
PCA-000-252	640	430	6,995 lbs	2,550 lbs	910 lbs	10,455 lbs

Note: N.T.S.

FLXX® 
Watertight
Front Range Precast Concrete, Inc.
 5439 N. Foothills Highway, Boulder, Colorado 80302
 Phone (303) 442-3207 • (800) 783-3207 • Fax (303) 442-3209
www.flxx.com