

1250 Gal. Grease Interceptor

FLXX®

FLXX®

TOP SLAB - TYPICAL REINFORCEMENT

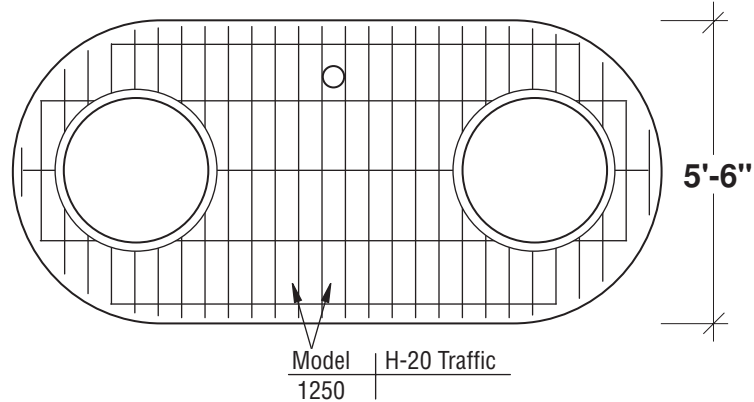

- Secondary chamber volume equal to 1/3 total capacity.
- Tanks meet or exceed ASTM-C-913 specifications for water and wastewater structures.
- Butyl rubber sealant meets or exceeds Fed. Spec. SS-S-210A. (Provided with tank)
- ASSHTO H-20 traffic rated.
- Plumbing shown in diagram provided by others.

SECTION

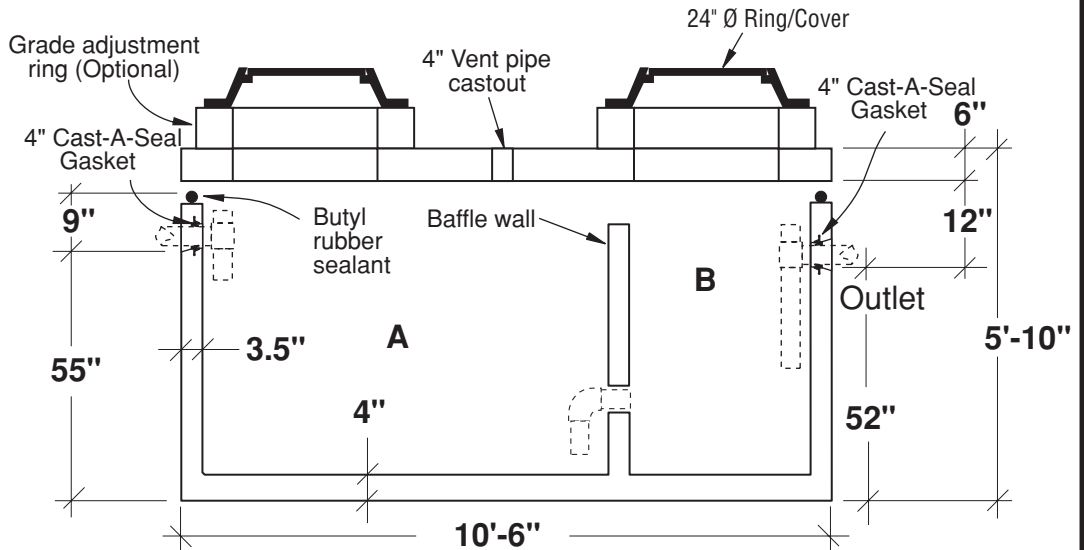

Part #	Capacities				Approximate Weights			
	Section/Gal.		Cubic Ft.		Tank	Lid	Baffle Wall	Total
PCA-000-271	A 835	B 555	A 110	B 72	8,430 lbs	3,370 lbs	910 lbs	12,710 lbs

Note: N.T.S.

FLXX® 
Watertight
Front Range Precast Concrete, Inc.
 5901 Dexter Street, Unit 200, Commerce City, CO 80022
 Phone (303) 442-3207 • (800) 783-3207 • Fax (303) 442-3209
www.flxx.com