

2000 Gal. Electric Lift Station

FLXX®

FLXX®

- Monolithic tank meets ASTM-C-1227 Spec. for water and wastewater structures.
- Butyl rubber sealant meets Fed. Spec. SS-S-210A. (Provided with tank)
- All plumbing shown in diagram is 4" SDR 35. (Provided with tank)

PLAN

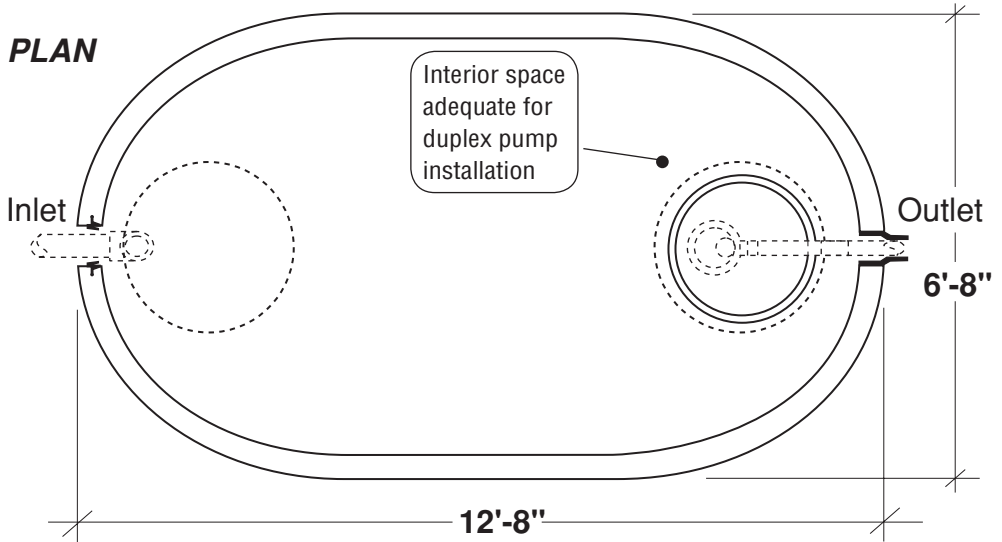

SECTION

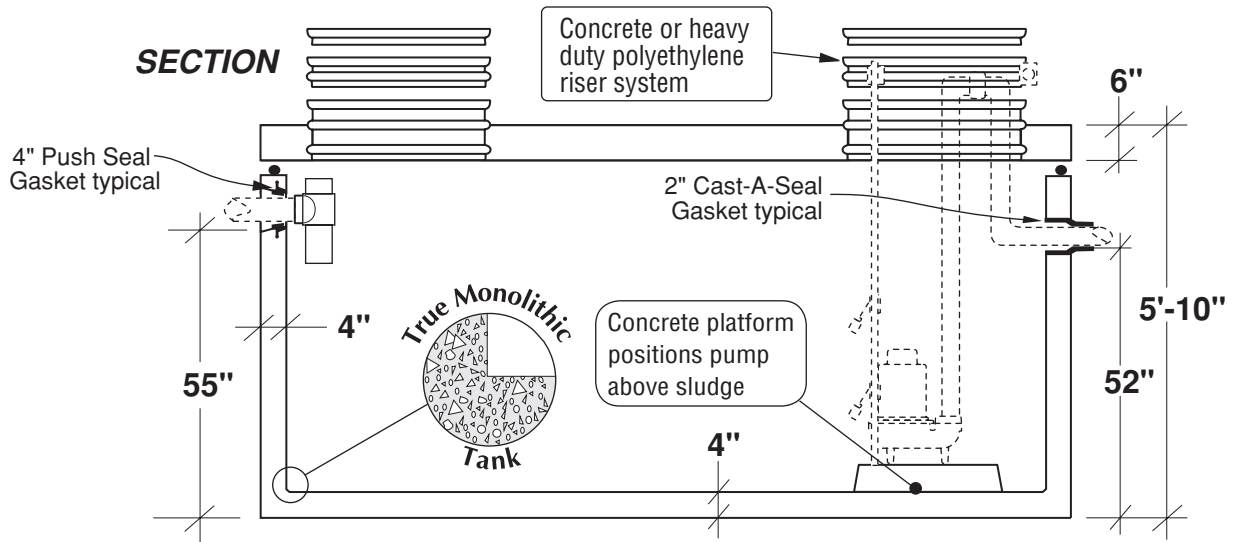

Part#	Discharge / Cycle	Approximate Weights		
		Tank	Lid	Total
PCA-000-299	40 Gal. / Vertical Inch (Variable)	11,690 lbs	5,145 lbs	16,835 lbs

Note: N.T.S.

FLXX® 
Watertight
Front Range Precast Concrete, Inc.
 5439 N. Foothills Highway, Boulder, Colorado 80302
 Phone (303) 442-3207 • (800) 783-3207 • Fax (303) 442-3209
www.flxx.com