

# 400 Gal. Electric Lift Station

FLXX®

FLXX®

- Monolithic tank meets ASTM-C-1227 Spec. for water and wastewater structures.
- Butyl rubber sealant meets Fed. Spec. SS-S-210A. (Provided with tank)
- All plumbing shown in diagram is 4" SDR 35. (Provided with tank)

PLAN

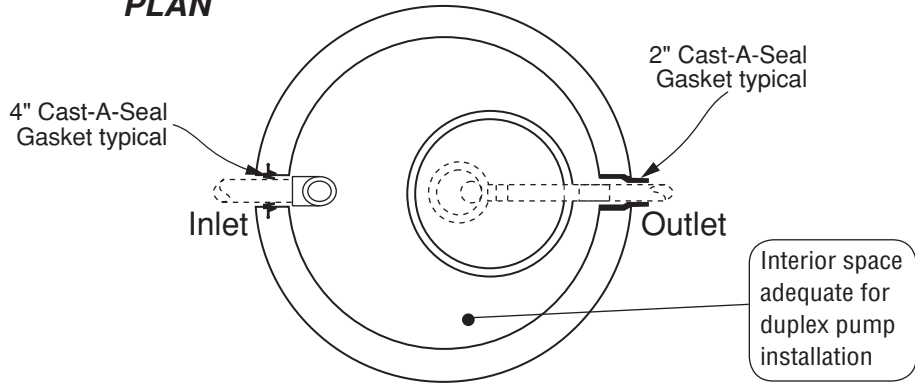

SECTION

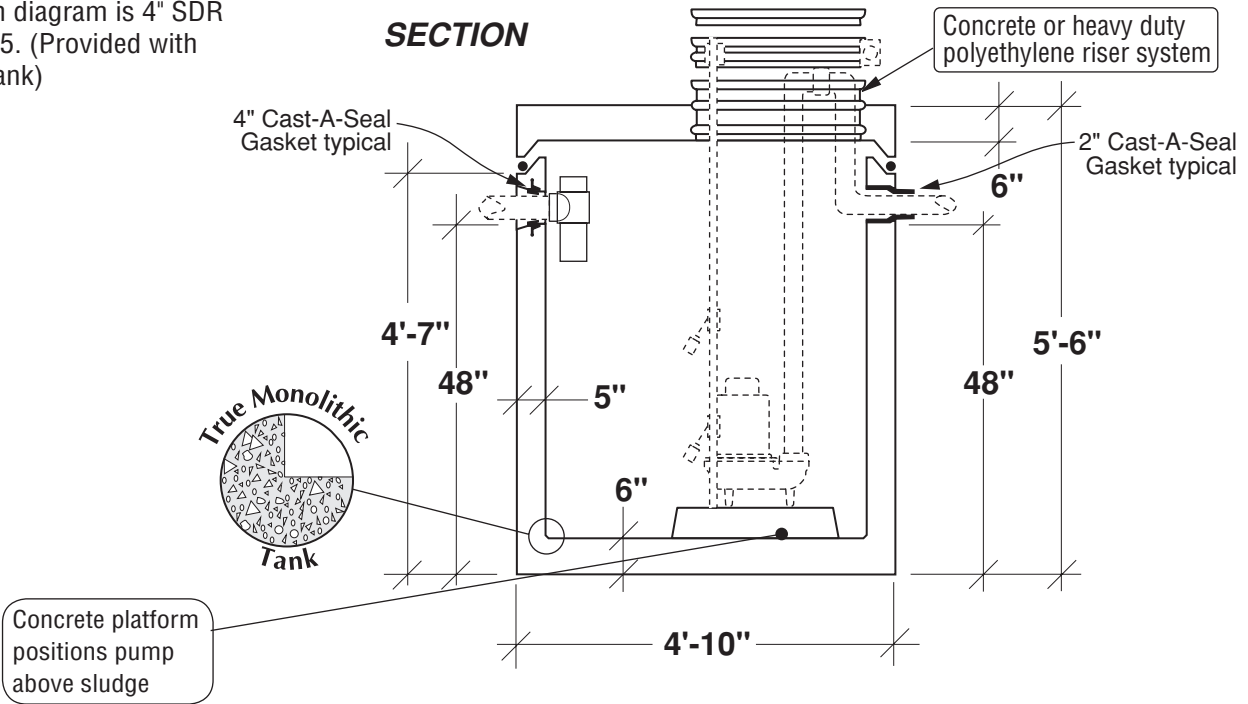

Part #	Discharge / Cycle	Approximate Weights		
		Tank	Lid	Total
PCA-000-294	7.8 Gal / Vertical Inch	4,850 lbs	1,520 lbs	6,370 lbs

Note: N.T.S.

**FLXX®**   
**Watertight**  
**Front Range Precast Concrete, Inc.**  
 5901 Dexter Street, Unit 200, Commerce City, CO 80022  
 Phone (303) 442-3207 • (800) 783-3207 • Fax (303) 442-3209  
[www.fxx.com](http://www.fxx.com)

# 500 Gal. Electric Lift Station

FLXX®

FLXX®

- Monolithic tank meets ASTM-C-1227 Spec. for water and wastewater structures.
- Butyl rubber sealant meets Fed. Spec. SS-S-210A. (Provided with tank)
- All plumbing shown in diagram is 4" SDR 35. (Provided with tank)

PLAN

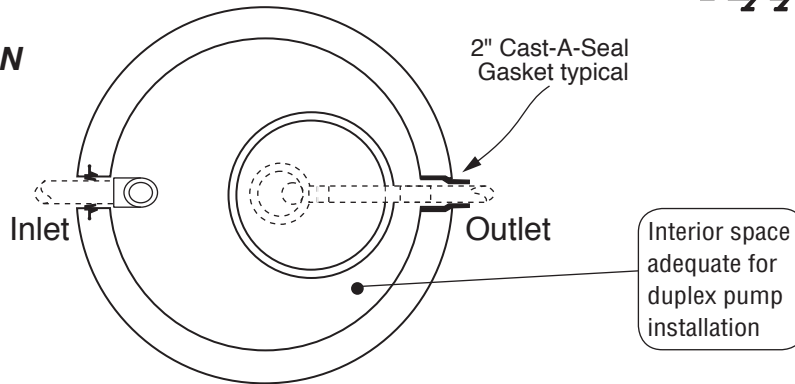

SECTION

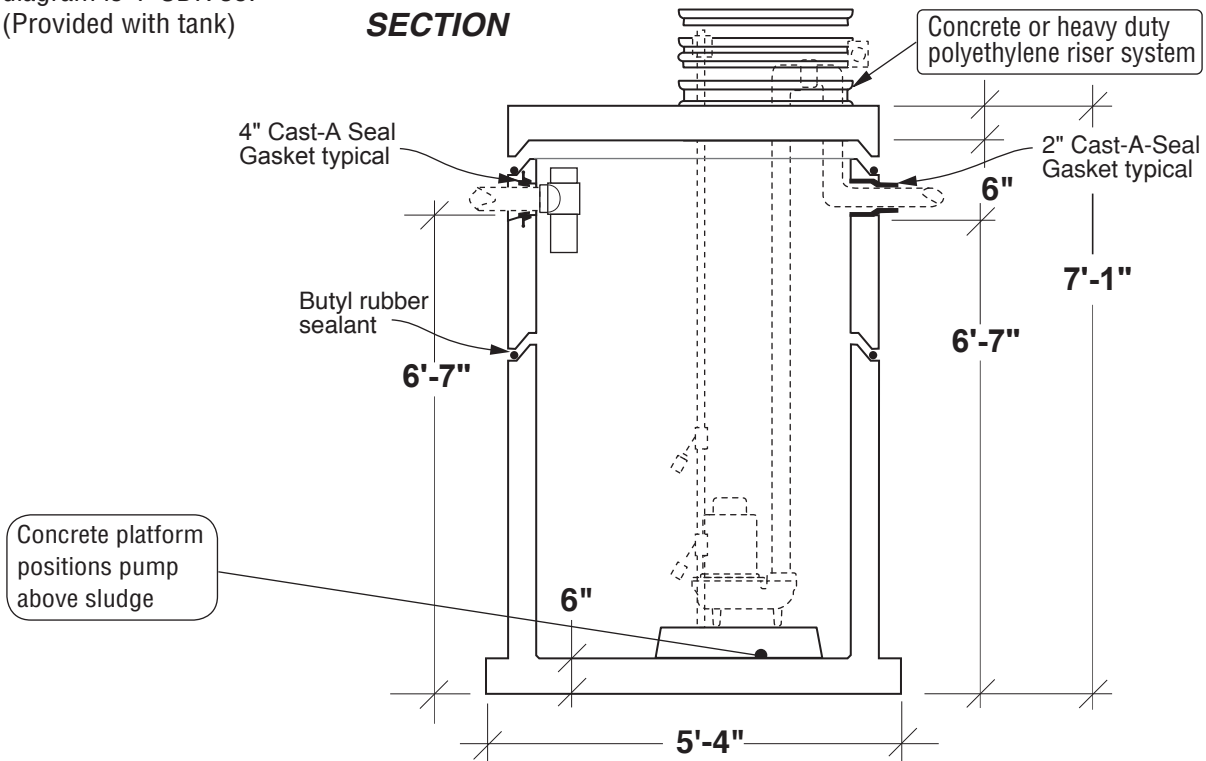

Part #	Discharge / Cycle	Approximate Weights			
		Tank Base	Tank Section	Lid	Total
PCA-000-295	7.8 Gal / Vertical Inch	4,340 lbs	1,740 lbs	1,520 lbs	7,600 lbs

Note: N.T.S.

**FLXX®**   
**Watertight**  
**Front Range Precast Concrete, Inc.**  
 5901 Dexter Street, Unit 200, Commerce City, CO 80022  
 Phone (303) 442-3207 • (800) 783-3207 • Fax (303) 442-3209  
[www.flxx.com](http://www.flxx.com)

# 1000 Gal. Electric Lift Station

FLXX®

FLXX®

- Monolithic tank meets ASTM-C-1227 Spec. for water and wastewater structures.
- Butyl rubber sealant meets Fed. Spec. SS-S-210A. (Provided with tank)
- All plumbing shown in diagram is 4" SDR 35. (Provided with tank)

## PLAN

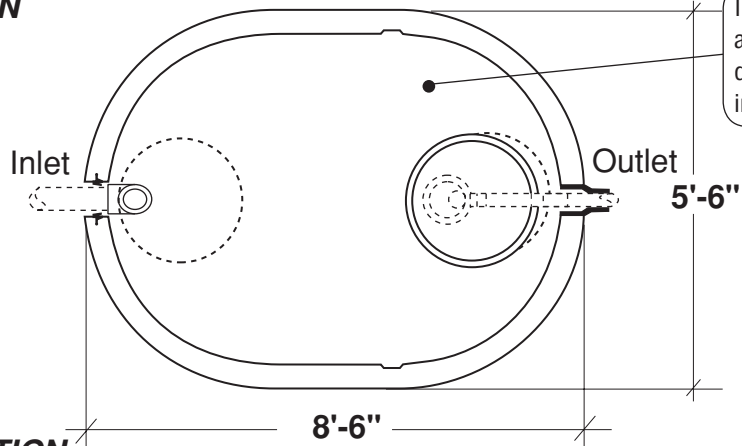

Interior space adequate for duplex pump installation

## SECTION

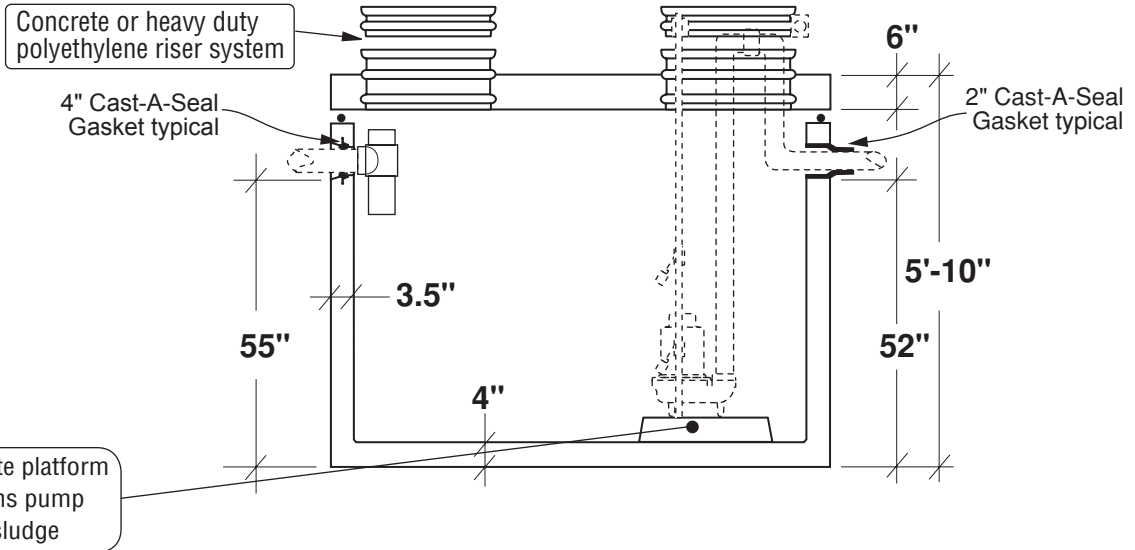

Concrete platform positions pump above sludge

Part #	Discharge / Cycle	Approximate Weights		
		Tank	Lid	Total
PCA-000-298	21.5 Gal/Vertical Inch	6,710 lbs	2,550 lbs	9,260 lbs

Note: N.T.S.



**Front Range Precast Concrete, Inc.**

5901 Dexter Street, Unit 200, Commerce City, CO 80022  
 Phone (303) 442-3207 • (800) 783-3207 • Fax (303) 442-3209  
[www.flxx.com](http://www.flxx.com)

# 2000 Gal. Electric Lift Station

FLXX®

FLXX®

- Monolithic tank meets ASTM-C-1227 Spec. for water and wastewater structures.
- Butyl rubber sealant meets Fed. Spec. SS-S-210A. (Provided with tank)
- All plumbing shown in diagram is 4" SDR 35. (Provided with tank)

**PLAN**

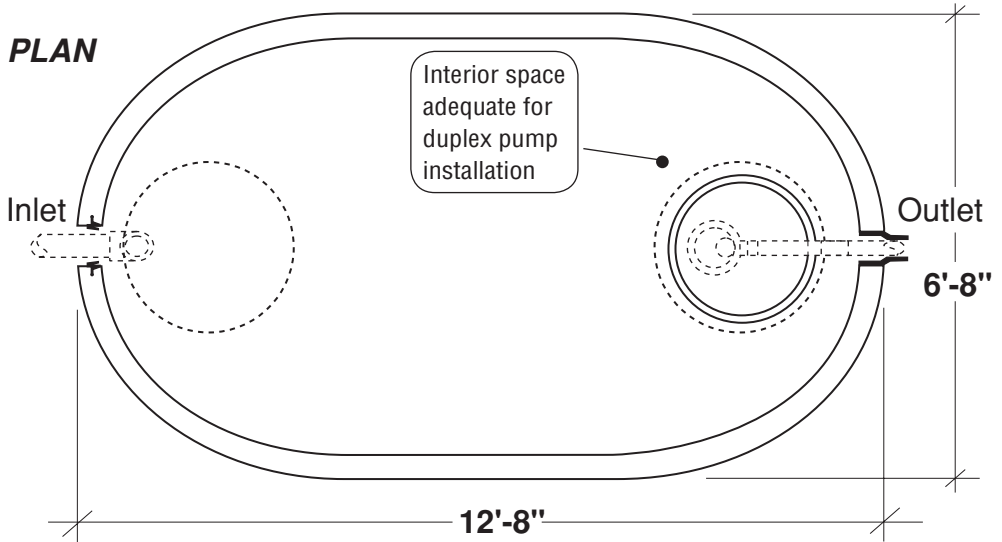

**SECTION**

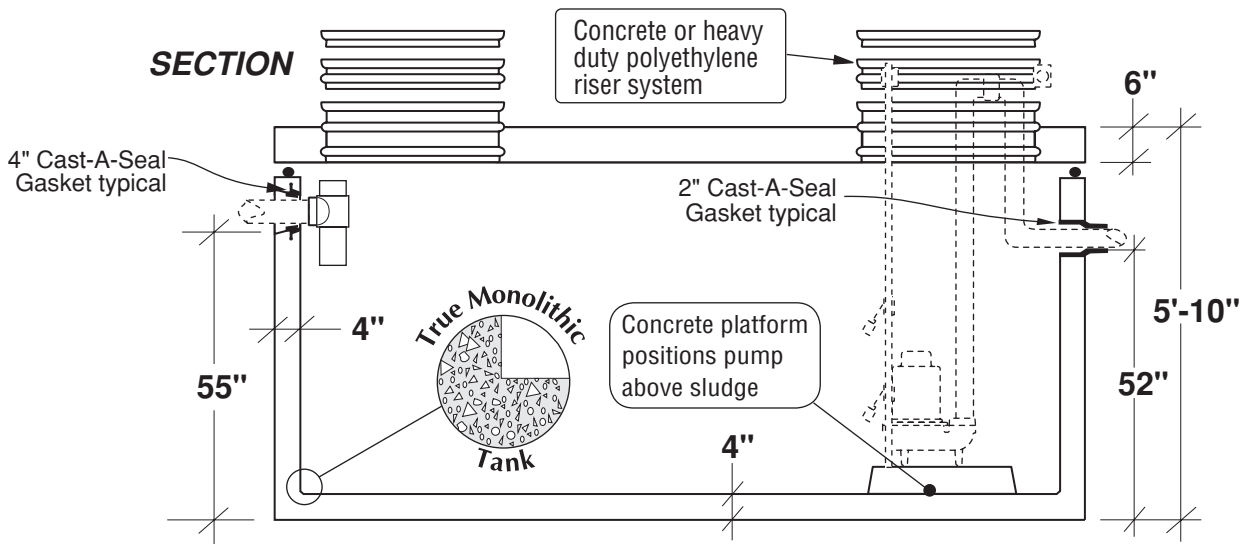

Part#	Discharge / Cycle	Approximate Weights		
		Tank	Lid	Total
PCA-000-299	40 Gal. / Vertical Inch (Variable)	11,690 lbs	5,145 lbs	16,835 lbs

Note: N.T.S.

**FLXX®**   
**Watertight**  
**Front Range Precast Concrete, Inc.**  
 5901 Dexter Street, Unit 200, Commerce City, CO 80022  
 Phone (303) 442-3207 • (800) 783-3207 • Fax (303) 442-3209  
[www.flxx.com](http://www.flxx.com)