

# Colorado HOOT® 4 Bedroom Siphon

FLXX®

FLXX®

- Monolithic tank meets ASTM-C-1227 Spec. for water and wastewater structures.
- Butyl rubber sealant meets Fed. Spec. SS-S-210A.
- See pages 35 - 41 for pumps and controls.
- Sensor tree
- Blower / Aerator
- #417 Siphon
- Optional remote monitoring system
- 2+ Years service
- 3 year parts warranty

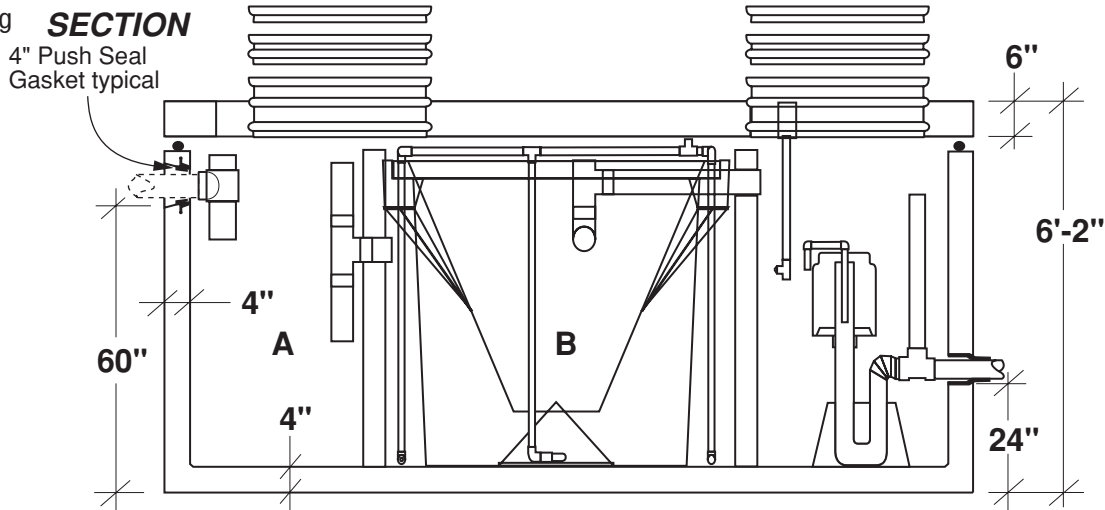
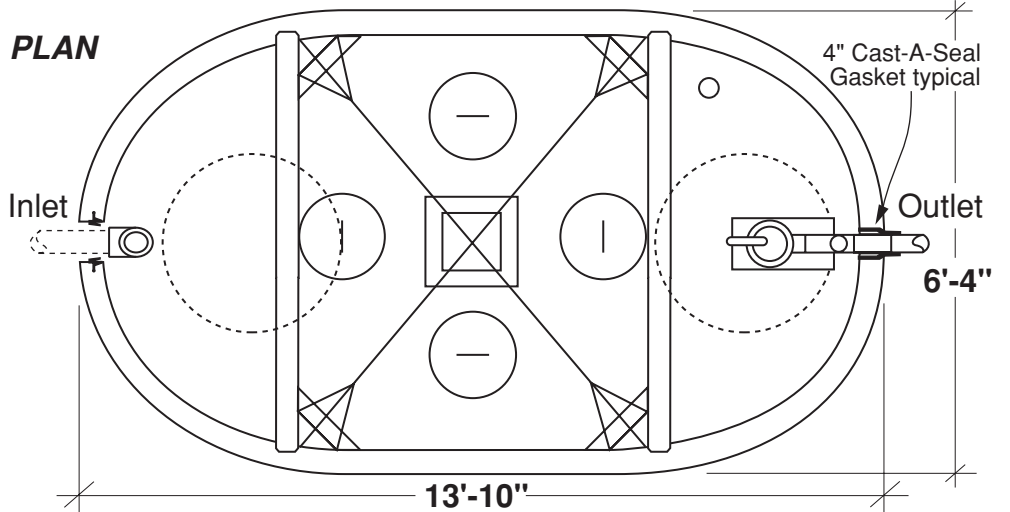

\* Includes 200 lbs. siphon / foundation

Part Number	Capacities (gallons)			Discharge Per Cycle (gallons)	Approximate Weights			
	A	B	Dosing Chamber		Tank*	Lid	Baffle Walls	Total
HCA-001-105	575	1120	605	185	12,090 lbs	5,165 lbs	2,880 lbs	20,135 lbs

Note: N.T.S.

**FLXX®**   
**Watertight**  
**Front Range Precast Concrete, Inc.**  
 5439 N. Foothills Highway, Boulder, Colorado 80302  
 Phone (303) 442-3207 • (800) 783-3207 • Fax (303) 442-3209  
[www.flxx.com](http://www.flxx.com)