

1000 Gal. Single Auto Siphon Chamber

FLXX®

FLXX®

- Monolithic tank meets ASTM-C-1227 Spec. for water and waste-water structures.
- Butyl rubber sealant meets Fed. Spec. SS-S-210A. (Provided with tank)
- All plumbing shown in diagram is 4" SDR 35. (Provided with tank)

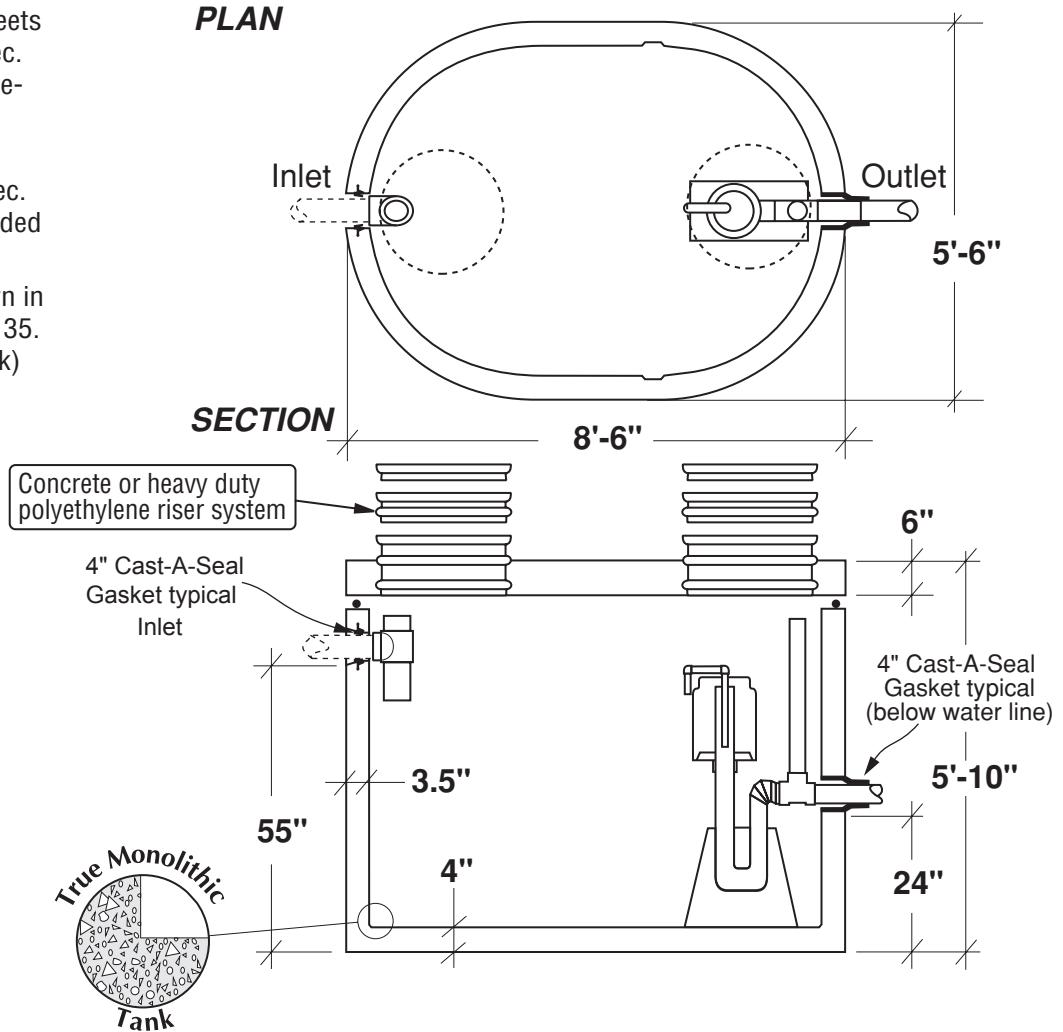

* Includes 200 lbs. siphon / foundation

Part #	Siphon / Discharge		Approximate Weights		
			Tank*	Lid	Total
PCA-000-289	#413	225 Gal.	6,910 lbs	2,550 lbs	9,460 lbs
PCA-001-289	#417	300 Gal.			

Note: N.T.S.

FLXX® 
Watertight
Front Range Precast Concrete, Inc.
 5901 Dexter Street, Unit 200, Commerce City, CO 80022
 Phone (303) 442-3207 • (800) 783-3207 • Fax (303) 442-3209
www.flxx.com