

# 400 Gal. Dual Alternating Auto Siphon Chamber

FLXX®

FLXX®

- Monolithic tank meets ASTM-C-1227 Spec. for water and waste-water structures.
- Butyl rubber sealant meets Fed. Spec. SS-S-210A. (Provided with tank)
- All plumbing shown in diagram is 4" SDR 35. (Provided with tank)

PLAN

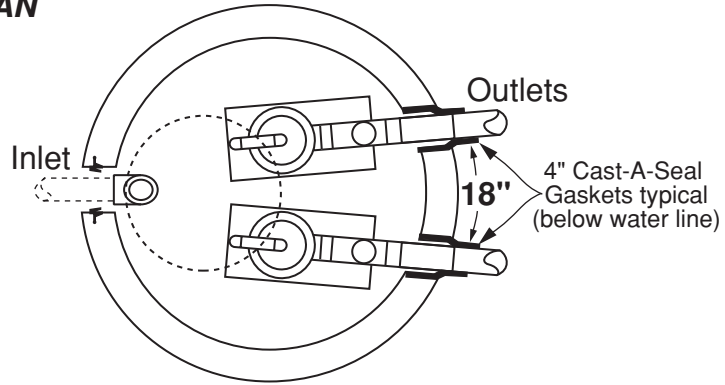

SECTION

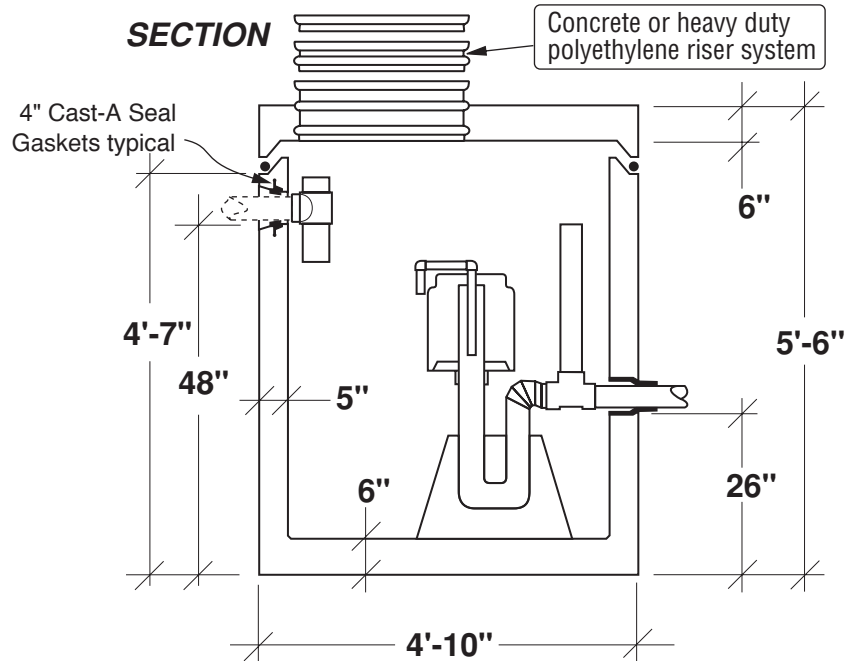

\* Includes (2) 200 lbs. siphon / foundations

Part #	Siphon / Discharge		Approximate Weights		
			Tank*	Lid	Total
PCA-000-281	#413	100 Gal.	5,250 lbs	1,520 lbs	6,770 lbs
PCA-001-281	#417	135 Gal.			

Note: N.T.S.

**FLXX®**   
**Watertight**

**Front Range Precast Concrete, Inc.**

5901 Dexter Street, Unit 200, Commerce City, CO 80022  
 Phone (303) 442-3207 • (800) 783-3207 • Fax (303) 442-3209

[www.fxx.com](http://www.fxx.com)

# 500 Gal. Dual Alternating Auto Siphon Chamber

FLXX®

FLXX®

- Monolithic tank meets ASTM-C-1227 Spec. for water and wastewater structures.
- Butyl rubber sealant meets Fed. Spec. SS-S-210A. (Provided with tank)
- All plumbing shown in diagram is 4" SDR 35. (Provided with tank)

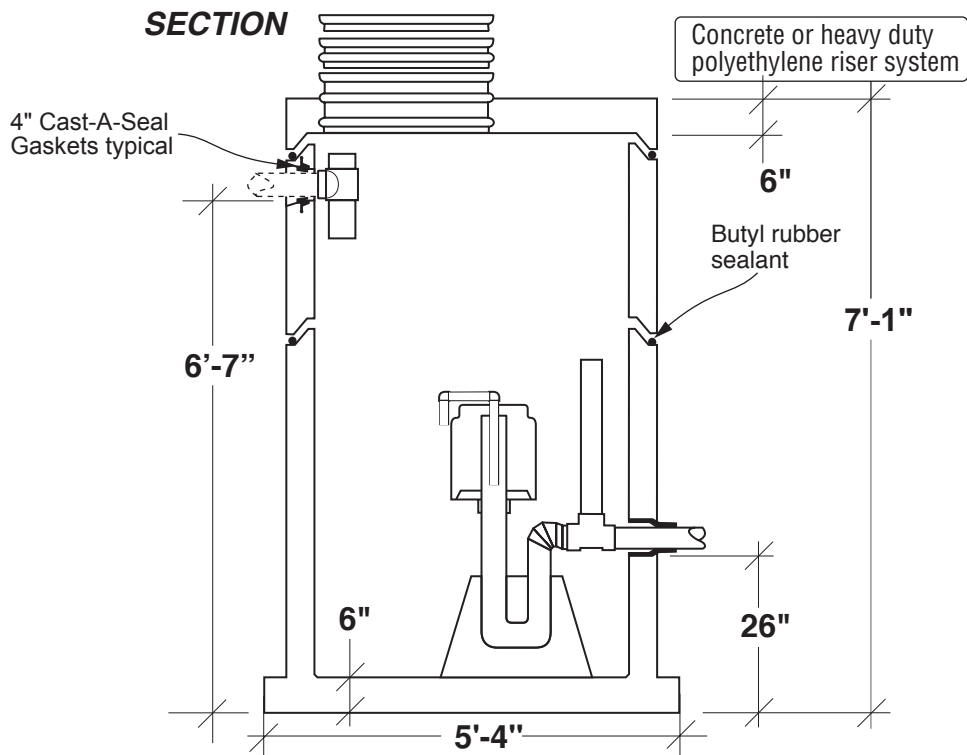
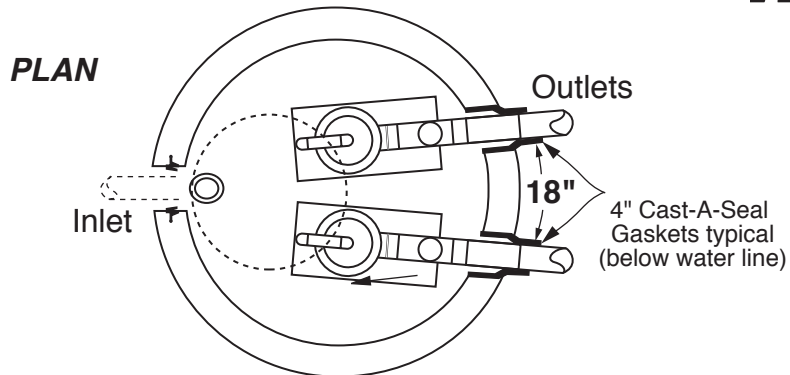

\* Includes (2) 200 lbs. siphon / foundations

Part #	Siphon/ Discharge		Approximate Weights			
			Bottom Section*	Top Section	Lid	Total
PCA-002-286	#423	180 Gal.	4,740 lbs	1,735 lbs	1,520 lbs	7,995 lbs

Note: N.T.S.

**FLXX®**   
Watertight

**Front Range Precast Concrete, Inc.**

5901 Dexter Street, Unit 200, Commerce City, CO 80022  
Phone (303) 442-3207 • (800) 783-3207 • Fax (303) 442-3209  
[www.flxx.com](http://www.flxx.com)

# 1000 Gal. Dual Alternating Auto Siphon Chamber

FLXX®

FLXX®

- Monolithic tank meets ASTM-C-1227 Spec. for water and wastewater structures.
- Butyl rubber sealant meets Fed. Spec. SS-S-210A. (Provided with tank)
- All plumbing shown in diagram is 4" SDR 35. (Provided with tank)

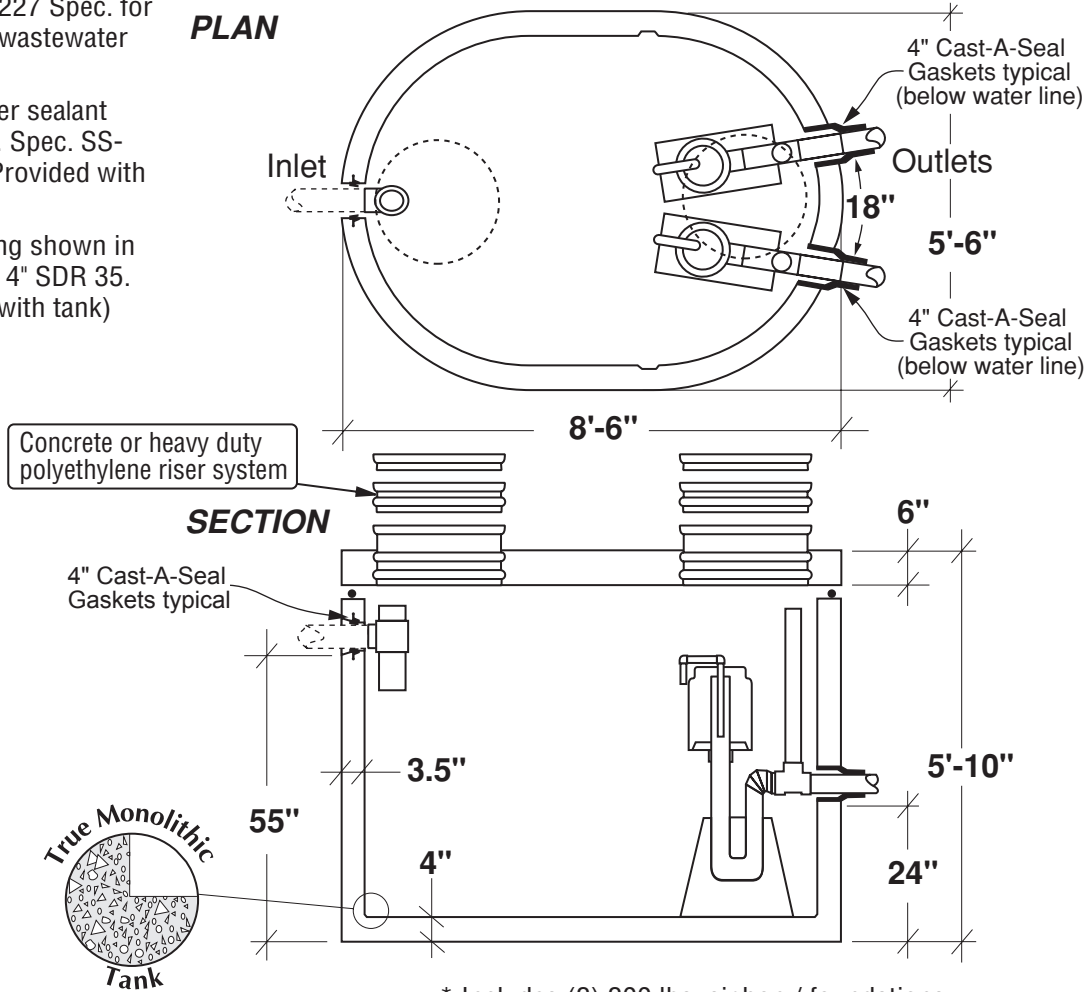

\* Includes (2) 200 lbs. siphon / foundations

Part #	Siphon / Discharge		Approximate Weights		
			Tank*	Lid	Total
PCA-000-290	#413	225 Gal.	7,110 lbs	2,550 lbs	9,670 lbs
PCA-001-290	#417	300 Gal.			

Note: N.T.S.

**FLXX®**   
**Watertight**  
**Front Range Precast Concrete, Inc.**  
 5901 Dexter Street, Unit 200, Commerce City, CO 80022  
 Phone (303) 442-3207 • (800) 783-3207 • Fax (303) 442-3209  
[www.flxx.com](http://www.flxx.com)

# 2000 Gal. Dual Alternating Auto Siphon Chamber

FLXX®

FLXX®

- Monolithic tank meets ASTM-C-1227 Spec. for water and wastewater structures.
- Butyl rubber sealant meets Fed. Spec. SS-S-210A. (Provided with tank)
- All plumbing shown in diagram is 4" SDR 35. (Provided with tank)

**PLAN**

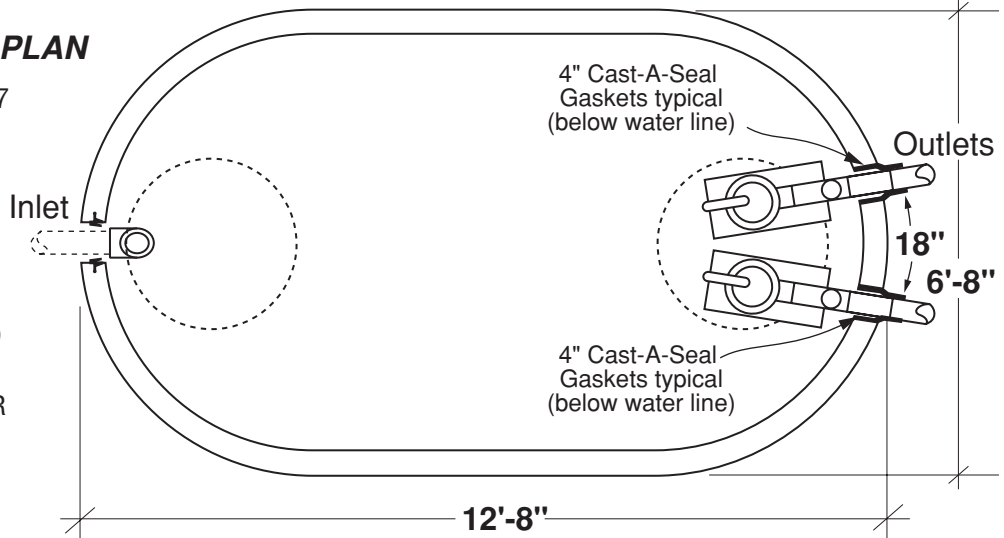

**SECTION**

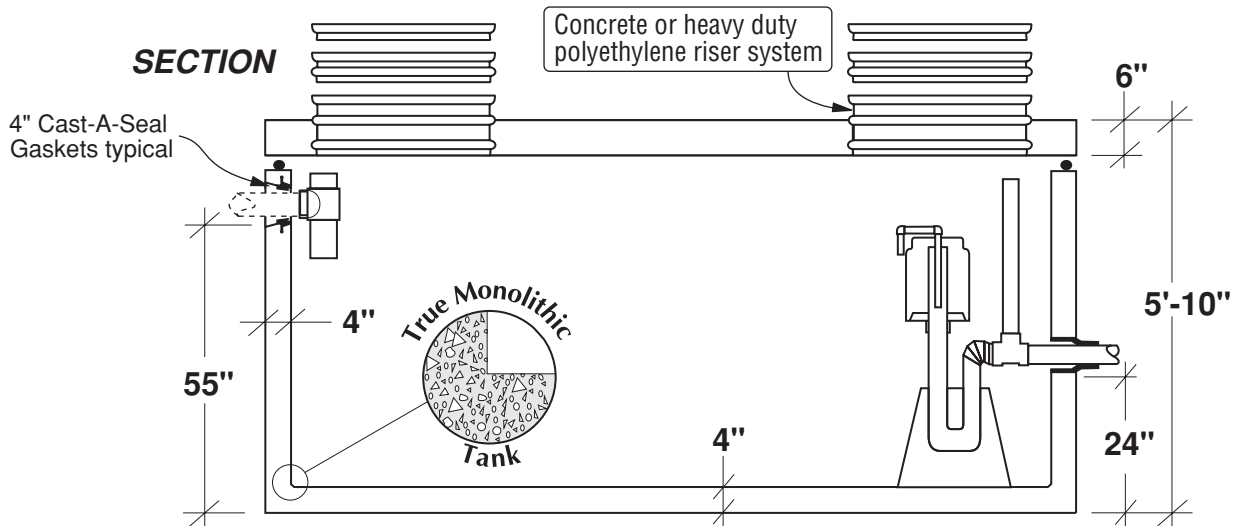

\* Includes (2) 200 lbs. siphon / foundations

Part #	Siphon / Discharge		Approximate Weights		
			Tank*	Lid	Total
PCA-000-292	#413	520 Gal.	12,090 lbs	5,145 lbs	17,235 lbs
PCA-001-292	#417	680 Gal.			

Note: N.T.S.

**FLXX®**   
Watertight

**Front Range Precast Concrete, Inc.**

5901 Dexter Street, Unit 200, Commerce City, CO 80022  
Phone (303) 442-3207 • (800) 783-3207 • Fax (303) 442-3209  
[www.flxx.com](http://www.flxx.com)